

RES-1000 USER

Intel® Core™ i7/i5/i3 SoC IP67 Rugged Embedded System
Multiple Waterproof M12 Connectors, Fanless -30°C to 70°C

Manual

Record of Revision

Version	Date	Page	Description	Remark
0.10	2019/12/30	All	Preliminary Release	
1.00	2020/01/03	All	Official Release	
1.10	2020/04/22	2	Update	
1.20	2020/07/03	13	Update	
1.30	2020/09/01	8	Update	
1.40	2022/07/04	46-48	Update	
1.50	2023/05/30	5, 41	Update	

Disclaimer

This manual is released by Vecow Co., Ltd. for reference purpose only. All product offerings and specifications are subject to change without prior notice. Vecow Co., Ltd. is under no legal commitment to the details of this document. Vecow shall not be liable for direct, indirect, special, incidental, or consequential damages arising out of the use of this document, the products, or any third party infringements, which may result from such use.

Declaration of Conformity

FCC This equipment has been tested and found to comply with the limits for a Class A digital device, pursuant to part 15 of the FCC Rules. These limits are designed to provide reasonable protection against harmful interference when the equipment is operated in a commercial environment. This equipment generates, uses, and can radiate radio frequency energy, and if it is not installed and used in accordance with the instruction manual, it may cause harmful interference to radio communications. Operation of this equipment in a residential area is likely to cause harmful interference in which case the user will be required to correct the interference at his own expense.

CE The products described in this manual comply with all applicable European Union (CE) directives if it has a CE marking. For computer systems to remain CE compliant, only CE-compliant parts may be used. Maintaining CE compliance also requires proper cable and cabling techniques.

Copyright and Trademarks

This document contains proprietary information protected by copyright. No part of this publication may be reproduced in any form or by any means, electric, photocopying, recording or otherwise, without prior written authorization by Vecow Co., Ltd. The rights of all the brand names, product names, and trademarks belong to their respective owners.

Order Information

Model Name	Processor	GigE LAN	COM	USB 2.0
RES-1000-600U	Intel® Core™ i7-6600U	2	2	2
RES-1000-300U	Intel® Core™ i5-6300U			
RES-1000-100U	Intel® Core™ i3-6100U			
RES-1000-955U	Intel® Celeron® 3955U			

Order Accessories

Part Number	Description
DDR4 16G	Certified DDR4 16GB 2133MHz RAM
DDR4 8G	Certified DDR4 8GB 2133MHz RAM
DDR4 4G	Certified DDR4 4GB 2133MHz RAM
2.5" SATA HDD	Certified 2.5" SATA HDD
2.5" SATA SSD	Certified 2.5" SATA SSD
mSATA SSD	Certified mSATA SSD
IP67 Rated DVI Cable	IP67 Rated DVI-D Cable, 200 cm
IP67 Rated Ethernet Cable	IP67 Rated M12 to RJ45 Ethernet Cable, 200 cm
IP67 Rated COM Cable	IP67 Rated M12 to COM Cable, 200 cm
PWA-120W	120W, 24V, 90V AC to 264V AC Power Adapter with 3-pin Terminal Block

Table of Contents

CHAPTER 1	GENERAL INTRODUCTION	1
1.1	Overview	1
1.2	Features	2
1.3	Product Specification	2
1.4	Supported CPU List	4
1.5	Mechanical Dimensions	4
CHAPTER 2	GETTING TO KNOW YOUR RES-1000	5
2.1	Packing List	5
2.2	Front Panel I/O Functions	6
2.3	Rear Panel I/O and Functions	6
CHAPTER 3	SYSTEM SETUP	10
3.1	How to Use Your RES-1000	10
3.2	Mount Your RES-1000	14
CHAPTER 4	BIOS SETUP	16
4.1	Entering Setup	16
4.2	Main Menu	17
4.3	Advanced Function	18
4.4	Chipset	28
4.5	Security	33
4.6	Boot	34
4.7	Save & Exit	35

APPENDIX A : Watchdog Function	37
APPENDIX B : Software Functions	39
APPENDIX C : RAID Functions	40
APPENDIX D : Power Consumption	44
APPENDIX E : Install Win11 (BIOS TPM Setting)	46

1

GENERAL INTRODUCTION

1.1 Overview

RES-1000 is an IP67 certified rugged Ultra-compact Fanless Embedded Box PC. Powered by 6th generation Intel® Core™ i7/i5/i3 processor (Skylake-U), DDR4 2133MHz up to 16GB memory, RES-1000 serves up to 222.9% CPU performance enhances than the fanless system powered by Intel Atom® E3845 processor; Advanced Intel® HD Graphics 520 graphics engine supports DirectX 12, OpenGL 4.5 and OpenCL 2.0 API; DVI-D display interface supports 1080p full HD resolution. Multiple Gen 3 PCIe (8GT/s), SATA III (6Gbps) and GigE (1Gbps) LAN make high-speed data conveying possible. Vecow RES-1000 Series Ultra-compact Fanless Embedded System delivers you outstanding Power-Efficient Performance for demanding workloads.

Featured with 2 independent rugged X-coded M12 GigE LANs support iAMT 11.0, 2 M12 COM RS-232/422/485, 1 M12 2-port USB 2.0, 1 IP67 waterproof DVI-D connector, 1 mSATA socket and 1 internal 2.5" SSD/HDD bracket, smart remote manageability, 9V to 36V wide range power input with M12 power connector, fanless -30°C to 70°C extended operating temperature, all-in-one IP67 compliant designs, RES-1000 is your trusted embedded engine for strict environmental requirements.

Vecow RES-1000 IP67 Certified Ultra-compact Fanless Embedded System delivers outstanding performance, compact integrated functions, smart manageability and rugged reliability for Smart Manufacturing, Rolling Stock, Environment Monitoring, Wayside Surveillance, Logging & Mining and any performance driven IIoT/Industry 4.0 applications in harsh environments.

1.2 Features

- Compact & slim design, IP67 protection
- Fanless, -30°C to 70°C Operating Temperature
- Intel® Core™ i7/i5/i3 U-series Processor (Skylake-U)
- DDR4 2133MHz memory, up to 16GB
- Intel® HD Graphics 520 supports DirectX 12, Open GL 4.5 and OpenCL 2.0
- IP67 waterproof DVI-D display interfaces supports 1080p full HD display
- 2 Independent X-coded M12 GigE LAN, iAMT 11.0 supported
- 2 M12 COM RS-232/422/485, 1 M12 for 2-port USB
- 9V to 36V DC Power Input, M12 waterproof connector
- One-stop customized Design and Manufacturing Services

1.3 Product Specification

System	
Processor	Intel® Core™ i7/i5/i3/Celeron® U-series Processor (Skylake-U)
Chipset	Intel® SoC
BIOS	AMI
SIO	IT8786E
Memory	1 DDR4 2133MHz SO-DIMM, up to 16GB
I/O Interface	
Serial	2 COM RS-232/422/485, A-coded M12 Connector
USB	1 supports 2-port USB 2.0, A-coded M12 Connector
LED	Power, HDD
Graphics	
Graphics Processor	Intel® HD Graphics 520
Interface	IP67 Waterproof DVI-D Connector, up to 1920 x 1200 @60Hz
Storage	
SATA	1 SATA III (6Gbps)
mSATA	1 SATA III (Mini PCIe Type, 6Gbps)
Storage Device	<ul style="list-style-type: none"> • 1 mSATA Socket • 1 Internal 2.5" SSD/HDD Bracket

Ethernet	
LAN 1	Intel® I219LM GigE LAN supports iAMT 11.0, X-coded M12 Connector
LAN 2	Intel® I210 GigE LAN, X-coded M12 Connector
Power	
Power Input	9V to 36V, DC-in
Power Interface	A-coded M12 Connector
Power Switch	IP67 Waterproof Power Button
Others	
Watchdog Timer	Reset : 1 to 255 sec./min. per step
Smart Management	Wake on LAN, PXE supported
HW Monitor	Monitoring temperature, voltages. Auto throttling control when CPU overheats.
Software Support	
Microsoft	Windows 10, Windows 8.1, Windows 7
Linux	Fedora 19, Ubuntu 10.04 LTS, or Linux Kernel 3.0 above
Mechanical	
Dimensions (WxDxH)	250mm x 180mm x 44mm (9.8" x 7.1" x 1.7")
Weight	2.3 kg (5.07 lb)
Mounting	<ul style="list-style-type: none"> • Wallmount by mounting bracket • VESA Mount
Environment	
Operating Temperature	-30°C to 70°C (-22°F to 158°F)
Storage Temperature	-40°C to 85°C (-40°F to 185°F)
Humidity	5% to 95% Humidity, non-condensing
Relative Humidity	95% at 70°C
Shock	<ul style="list-style-type: none"> • IEC 60068-2-27 • SSD : 50G @ Wallmount, Half-sine, 11ms
Vibration	<ul style="list-style-type: none"> • IEC 60068-2-64 • SSD : 5Grms, 5Hz to 500Hz, 3 Axis
EMC	CE, FCC, EN50155, EN50121-3-2

1.4 Supported CPU List

Processor No.	TDP	Cache	Max. Frequency	Embedded
i7-6600U	15W	4M	Up to 3.4 GHz	Yes
i5-6300U	15W	3M	Up to 3.0 GHz	Yes
i3-6100U	15W	3M	Up to 2.3 GHz	Yes
Celeron 3955U	15W	2M	Up to 2.0 GHz	Yes

1.5 Mechanical Dimensions

Unit: mm (inch)

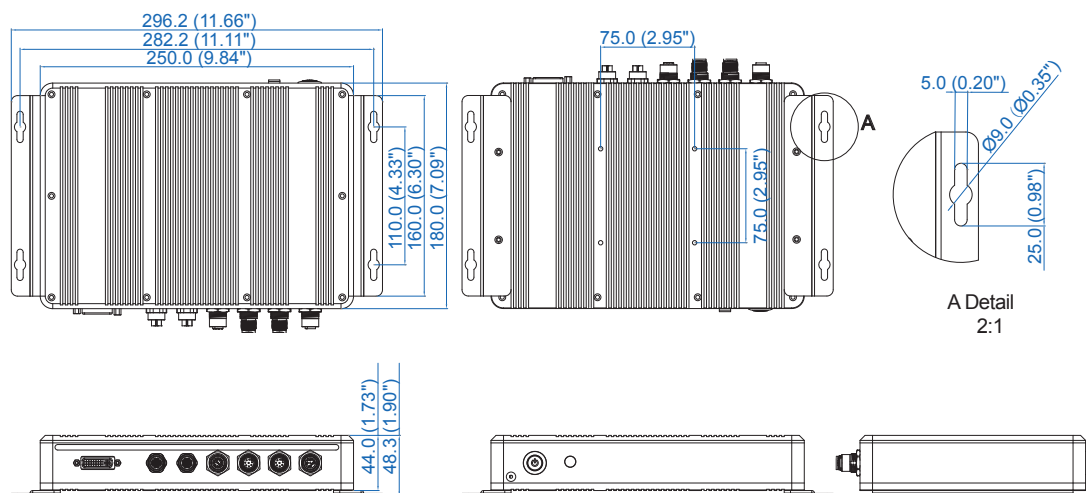

2

GETTING TO KNOW YOUR RES-1000

2.1 Packing List

Item	Description	Qty
1	RES-1000 Rugged Embedded System	1
2	Wall Mount Kit	2
3	PHILLIPS F#6-32 screws for wall mount kit	4
4	M12 to USB cable (2M Length)	1
5	M12 to DC terminal block cable (2M Length)	1



2.2 Front Panel I/O Functions

2.2.1 Power Button

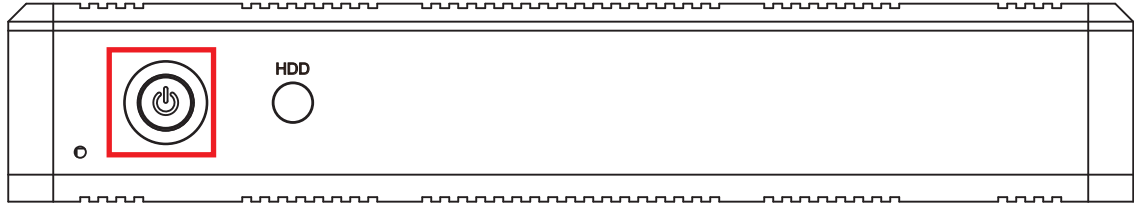

The power button is a non-latched switch. In case of system halts, you can press and hold the power button for 4 seconds to compulsorily shut down the system. Please note that a 4 seconds interval is kept by the system between two on/off operations (i.e. once turning off the system, you shall wait for 4 seconds to initiate another power-on operation).

LED Color	Power Status	System Status
Blue	Power	System power status (on/off)

2.2.2 HDD LED Indicator

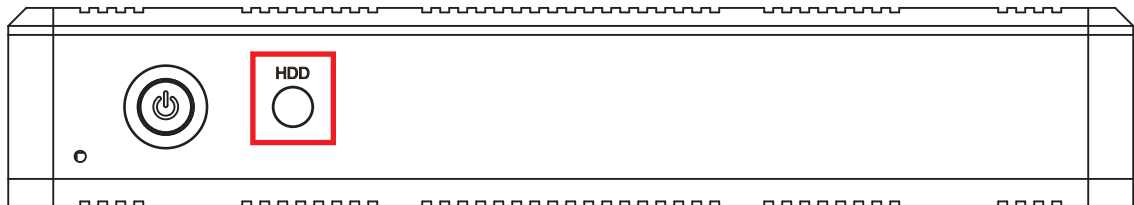

Orange-HDD LED: A hard disk LED. If the LED is on, it indicates that the system's storage is functional. If it is off, it indicates that the system's storage is not functional. If it is flashing, it indicates data access activities are in progress.

LED Color	Power Status	System Status
Orange	HDD	<ul style="list-style-type: none">• On/Off : Storage status, function or not.• Twinkling : Data transferring.

2.3 Rear Panel I/O and Functions

In Vecow's RES-1000, all I/O connectors are located on the Rear panel. Most of the general connections to the computer device, such as DVI-D, M12 jack for LAN,USB2.0,COM port and DC-IN , are placed on the Rear panel.

2.3.1 DVI Connector

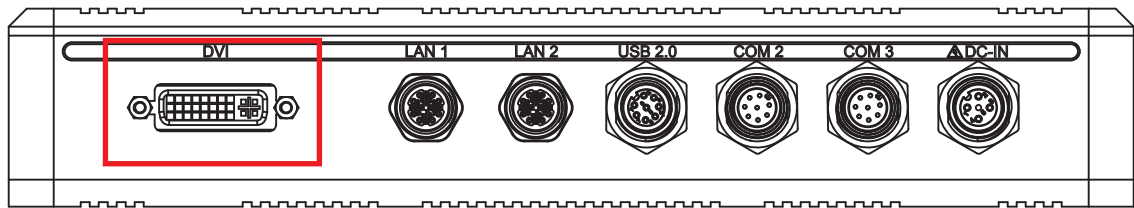

The DVI connector on the rear panel supports only DVI-D display. This connector can either output DVI signal. The DVI output mode supports up to 1920 x 1200 resolution and output mode supports up to 1920 x 1200 resolution. The DVI is automatically selected according to the display device connected. You will need a DVI-D cable when connecting to a display device.

2.3.2 10/ 100/ 1000 Mbps Ethernet Port

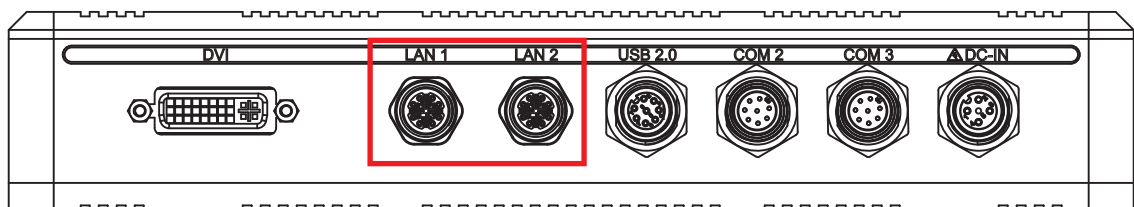

There are 2 M12 jacks supporting 10/ 100/1000 Mbps Ethernet connections in the rear side. LAN 1 is powered by Intel I219 Ethernet engine; LAN 2 is powered by Intel i210 Ethernet Phy. When both LAN 1 and LAN 2 work in normal status, iAMT 11.0 function is enabled. Using suitable M12 LAN cable, you can connect the system to a computer, or to any other devices with Ethernet connection, for example, a hub or a switch. Moreover, both of LAN 1 and LAN 2 supports Wake on LAN and Pre-boot functions. The pin-outs of LAN 1 and LAN 2 are listed as follows:



Pin No.	LAN1	LAN2
1	LAN0_MDI_1P	LAN1_MDI_1P
2	LAN0_MDI_1P	LAN1_MDI_1P
3	LAN0_MDI_2N	LAN1_MDI_2N
4	LAN0_MDI_2P	LAN1_MDI_2P
5	LAN0_MDI_4P	LAN1_MDI_4P
6	LAN0_MDI_4N	LAN1_MDI_4N
7	LAN0_MDI_3N	LAN1_MDI_3N
8	LAN0_MDI_3P	LAN1_MDI_3P

2.3.3 USB 2.0

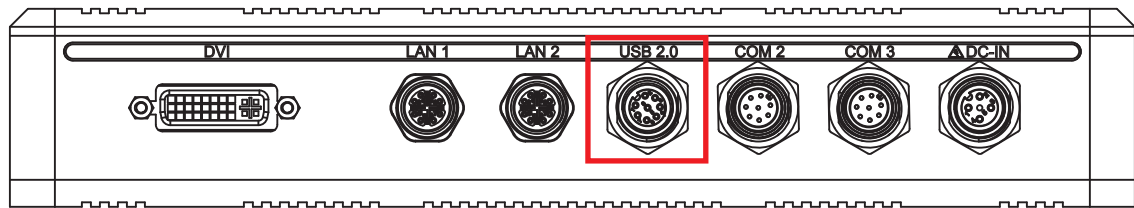

There are 2 USB 2.0 connections available supporting up to 480MB per second data rate.

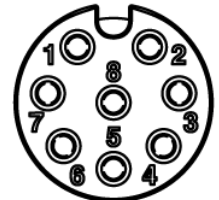

The pin-outs of USB2.0 are listed as follows:

Pin No.	USB2.0	Pin No.	USB2.0
1	USB_1D-	5	USB_2D-
2	USB_1D+	6	USB_2D+
3	USB_VCC	7	USB_VCC
4	USB_GND	8	USB_GND

2.3.4 Serial Port COM 2 and COM 3

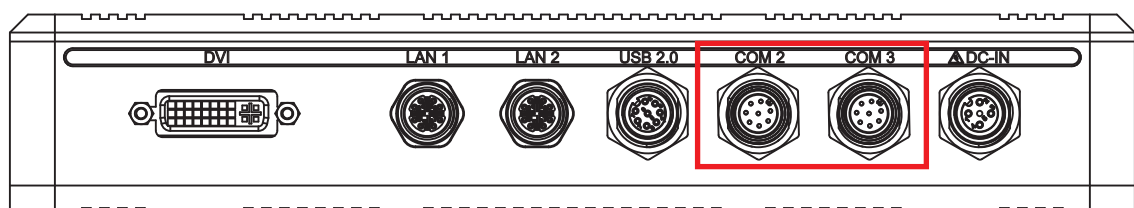

Serial port COM2 and COM3 can be configured for RS-232, RS-422, or RS-485 with auto flow control communication. The default definition of COM 1 and COM 2 is RS-232, if you want to change to RS-422 or RS-485, you can find the setting in BIOS.

The pin-outs of COM2 and COM3 are listed as follows:



Serial Port	Pin No.	RS-232	RS-422 (5-wire)	RS-422 (9-wire)	RS-485 (3-wire)
COM2	1	DCD	TXD-	TXD-	DATA-
	2	RXD	TXD+	TXD+	DATA+
	3	TXD	RXD+	RXD+	-----
	4	DTR	RXD-	RXD-	-----
COM3	5	DSR	-----	RTS-	-----
	6	RTS	-----	RTS+	-----
	7	CTS	-----	CTS+	-----
	8	GND	GND	GND	GND

2.3.5 DC JACK

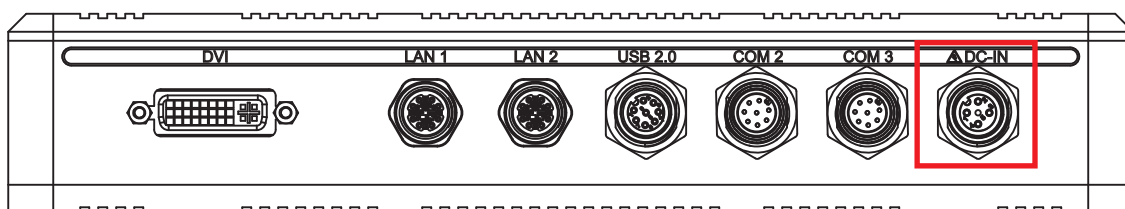

This system supports 9V to 36V DC power input by M12 DC Cable in the rear side. RES-1000

The pin-outs of DC-IN jack are listed as follows:

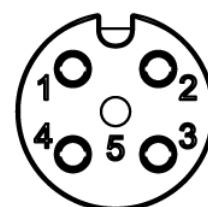

Pin No.	DC-IN	Pin No.	USB2.0
1	VIN	4	GND
2	VIN	5	NC
3	GND		

3

SYSTEM SETUP

3.1 How to Use Your RES-1000

3.1.1 M12 A code/X code

Step 1 Remove M12 cover. (Example DC-IN)



Step 2 Confirm M12 connector pin defined.



Step 3 Confirm wire.



Step 4 Turn wire connector.



Step 5 Locked.



3.1.2 DVI

Step 1 Remove DVI cover.



Step 2 Confirm DVI connector pin defined.



Step 3 Confirm wire.



Step 4 Turn wire connector.



Step 5 Locked.



Reminder: To ensure IP67 protection, we strongly discourage users from opening the chassis of RES-1000. After reassembly, RES-1000 will no longer be IP67 compliant unless the system goes through another Air Compressor Test.

3.2 Mount Your RES-1000

3.2.1 Wall Mount

Step 1 Fasten four PHILLIPS #6-32 screws.

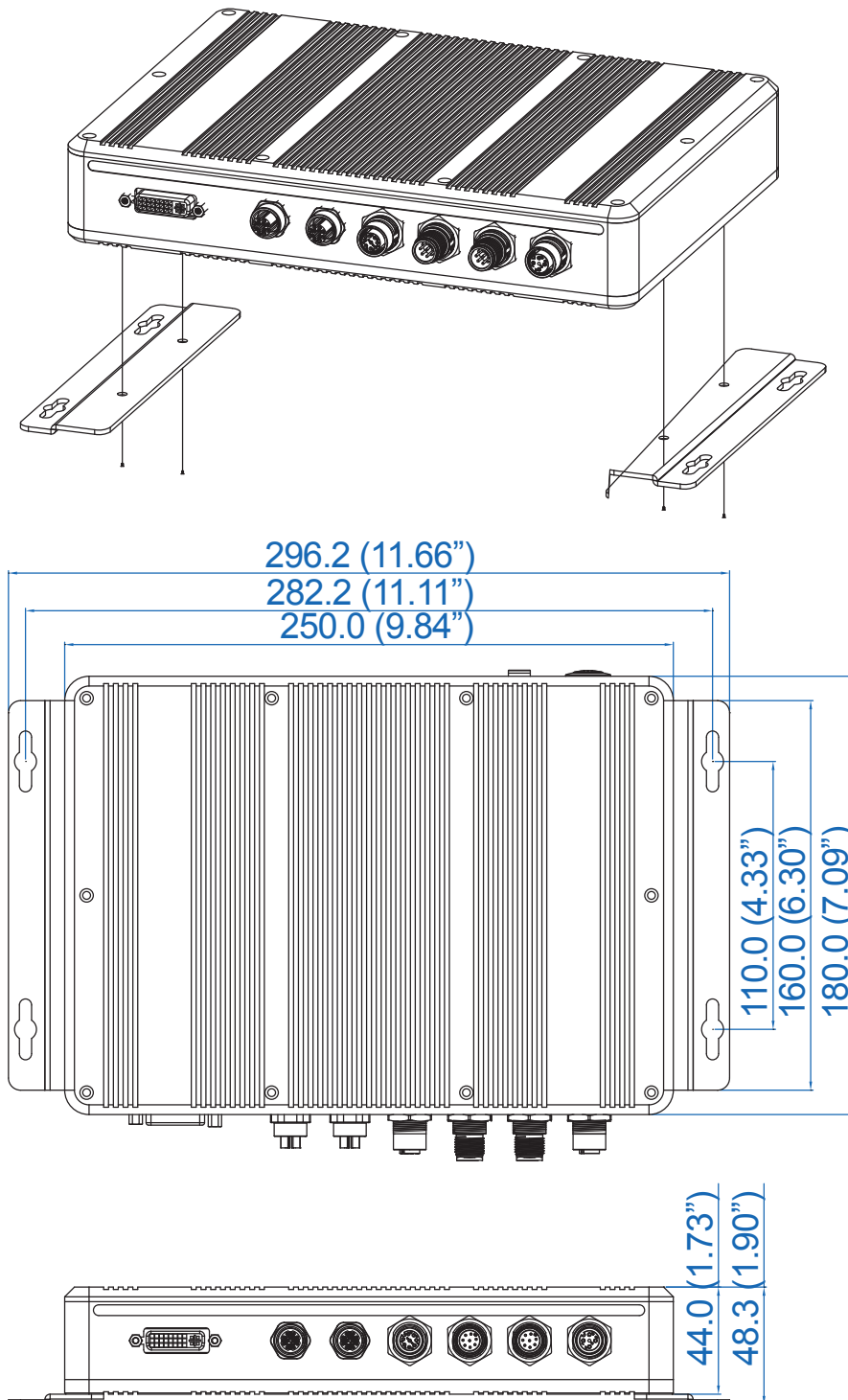

3.2.2 VESA Mount (75x75 mm)

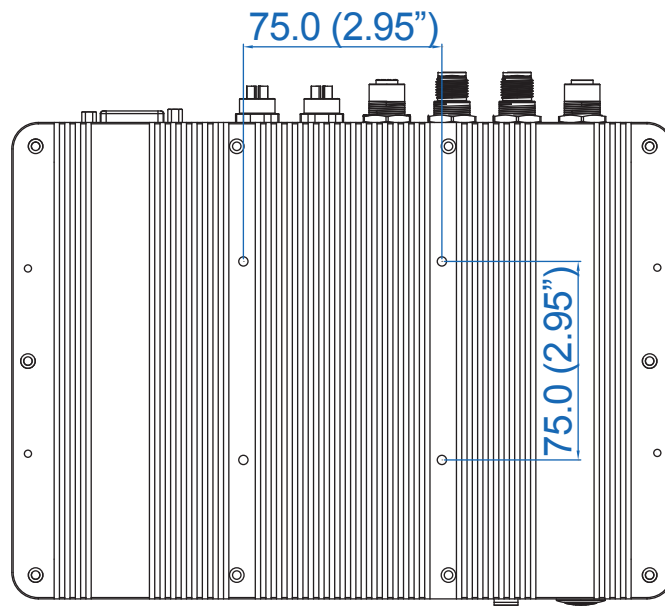

4

BIOS SETUP

4.1 Entering Setup

BIOS provides an interface for users to check and change system configuration. The BIOS setup program is accessed by pressing the key when POST display output is shown.

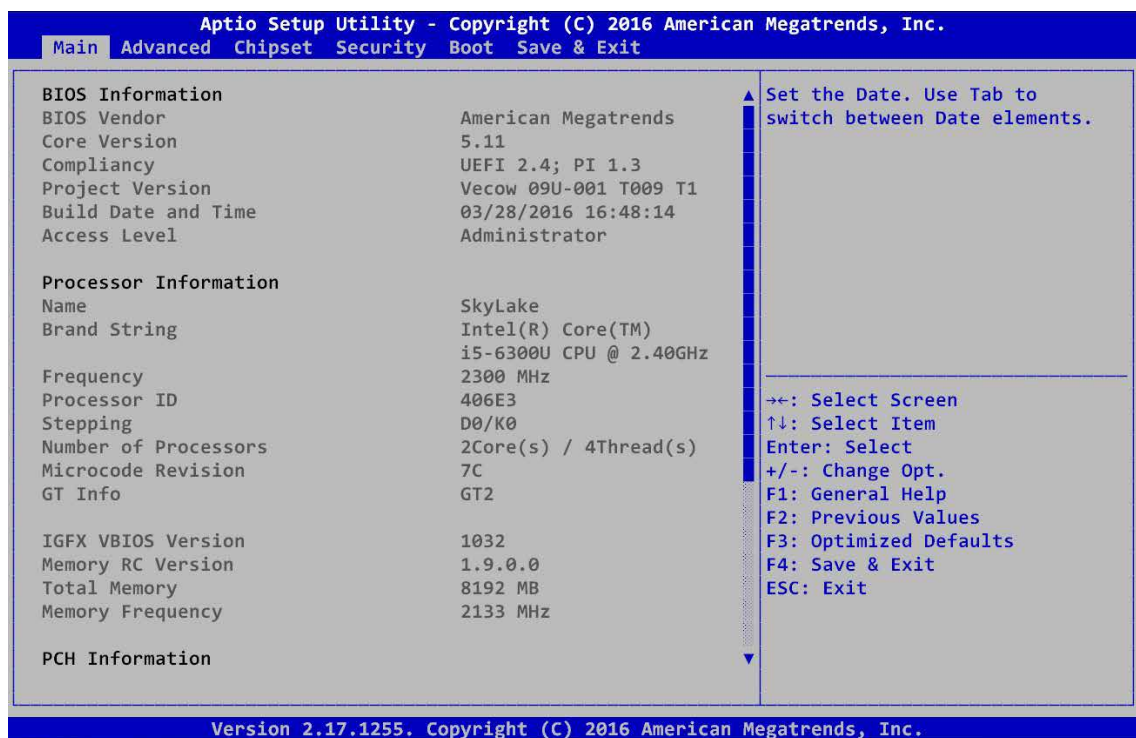

Figure 4-1 : Entering Setup Screen

4.2 Main Menu

The main menu displays BIOS version and system information. There are two options on Main menu.

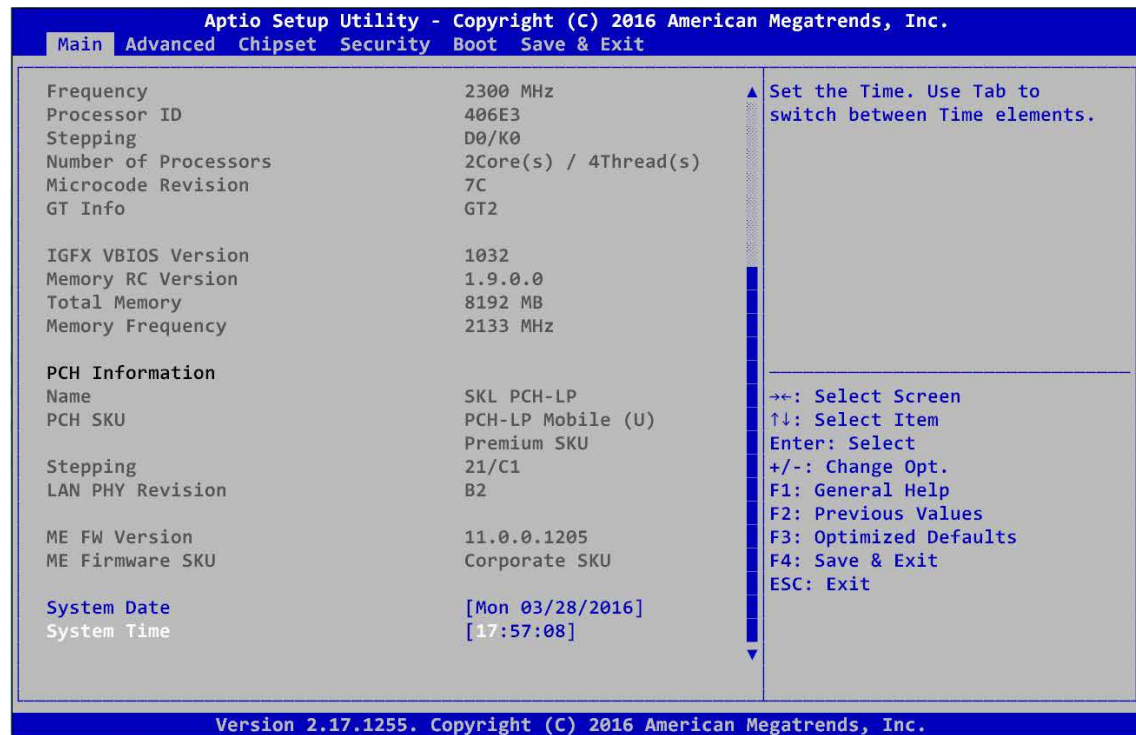

Figure 4-2 : BIOS Main Menu

System Date

Set the Date. Use Tab to switch between Date elements.

System Time

Set the Time. Use Tab to switch between Time elements.

4.3 Advanced Function

Select advanced tab to enter advanced BIOS setup options, such as CPU configuration, SATA configuration, and USB configuration.

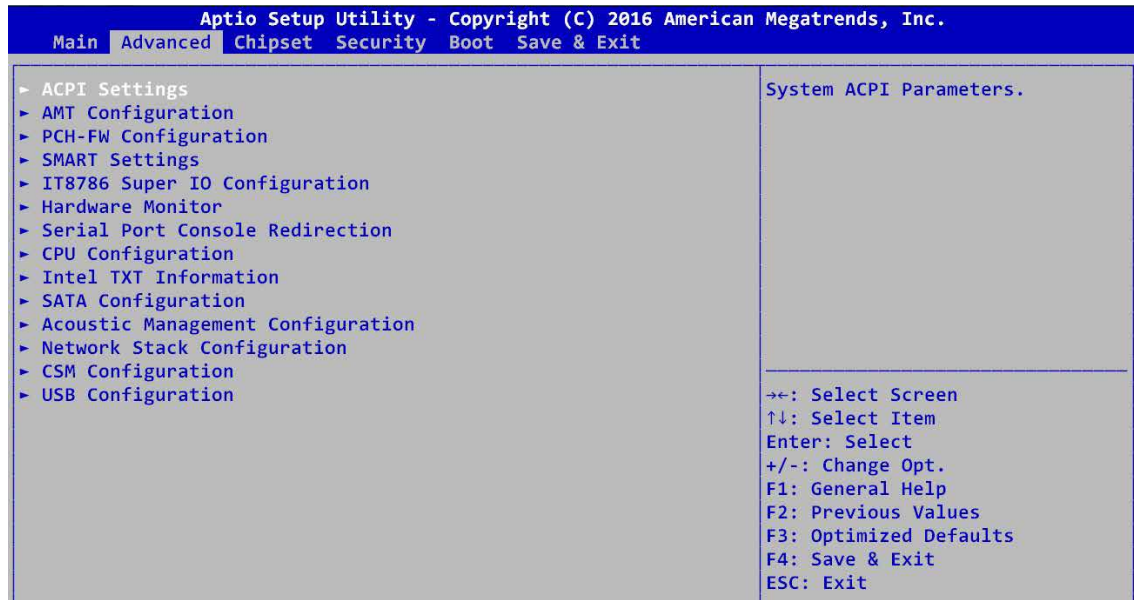

Figure 4-3 : BIOS Advanced Menu

4.3.1 ACPI Setting

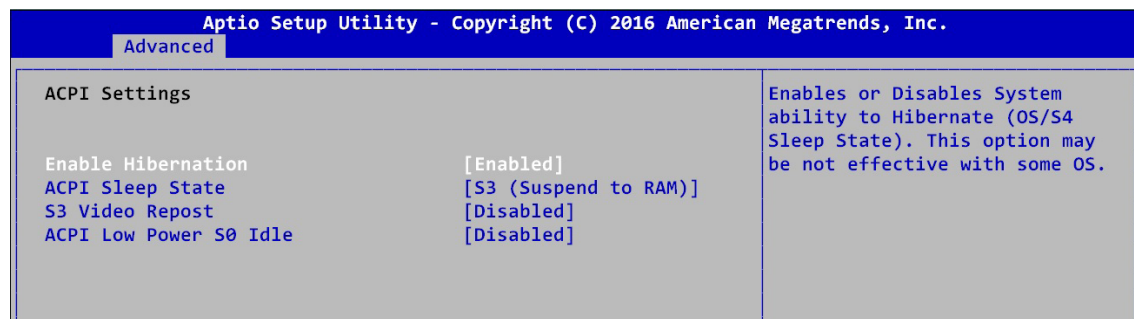

Figure 4-3-1 : ACPI Settings

Enable Hibernation

Enables or disables system's ability to hibernate (OS/S4 Sleep State). This option may be not effective with some OS.

ACPI Sleep State

Select the highest ACPI sleep state the system will enter when the SUSPEND button is pressed.

S3 Video Repost

Enable or disable S3 Video Repost.

ACPI Low Power S0 Idle

Enable or disable ACPI Low Power S0 Idle Support.

4.3.2 AMT Configuration

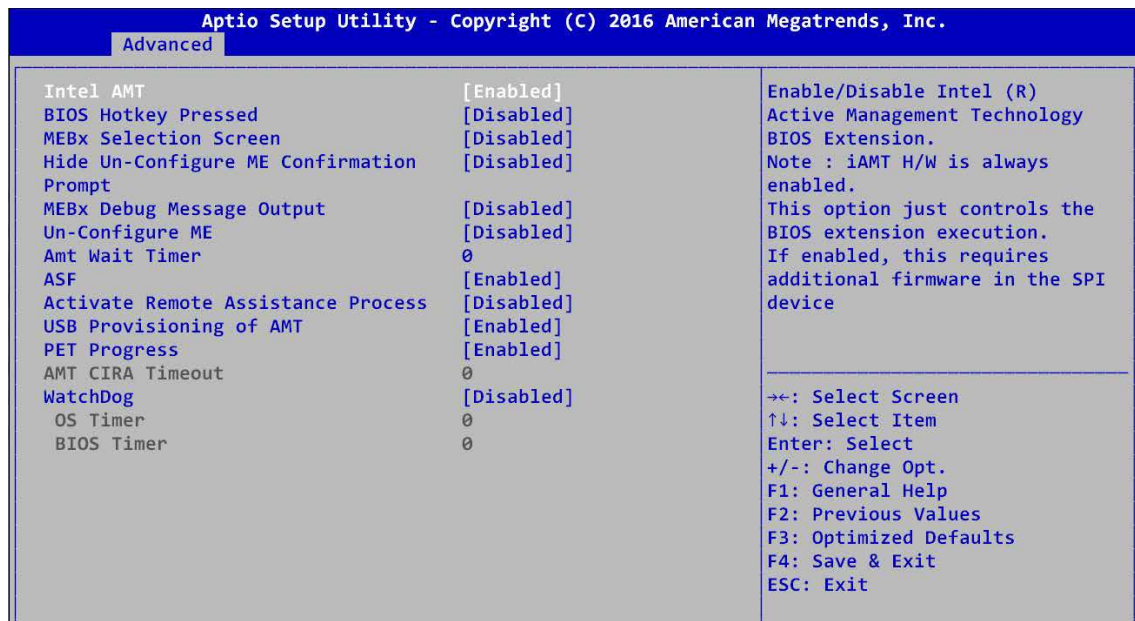

Figure 4-3-2 : Intel AMT Settings

Intel AMT

Enable/disable Intel Active Management Technology BIOS Extension.

Note: iAMT H/W is always enabled. This option just controls the BIOS extension execution. If enabled, this requires additional firmware in the SPI device.

4.3.3 PCH-FW Configuration

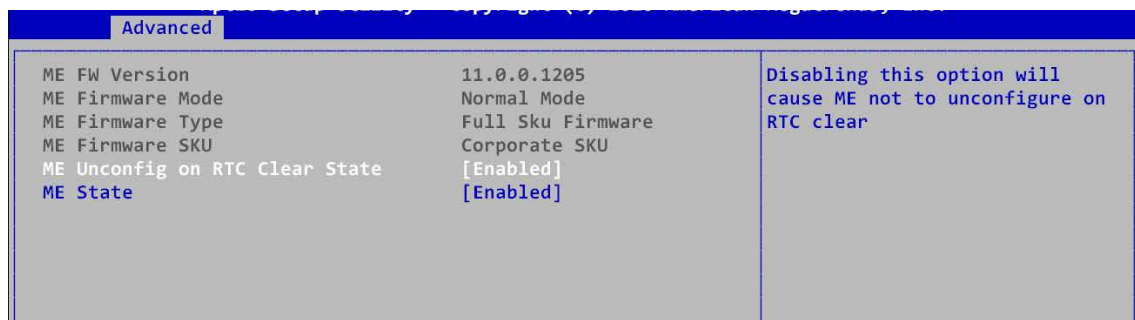

Figure 4-3-3 : PCH-FW Settings

ME Unconfig on RTC Clear State

Disabling this option will cause ME not to unconfigure on RTC clear.

ME State

Set ME to soft temporarily disabled.

4.3.4 SMART Settings

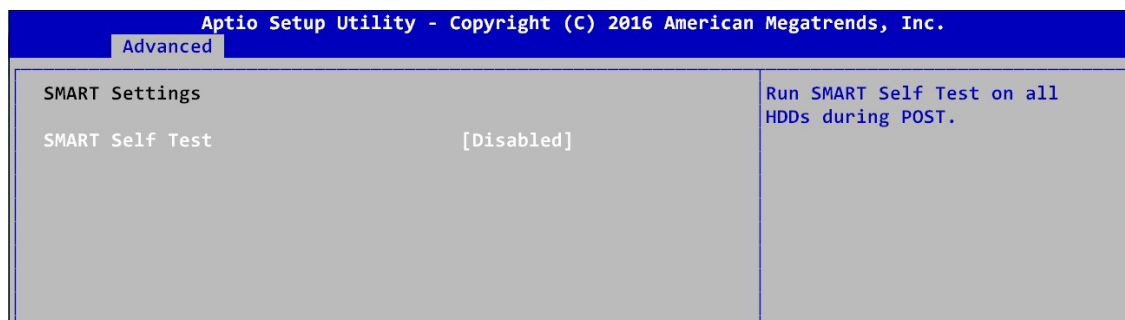

Figure 4-3-4 : SMART Settings

SMART Self Test

Run SMART Self Test on all HDDs during POST.

4.3.5 IT8786 Super IO Configuration

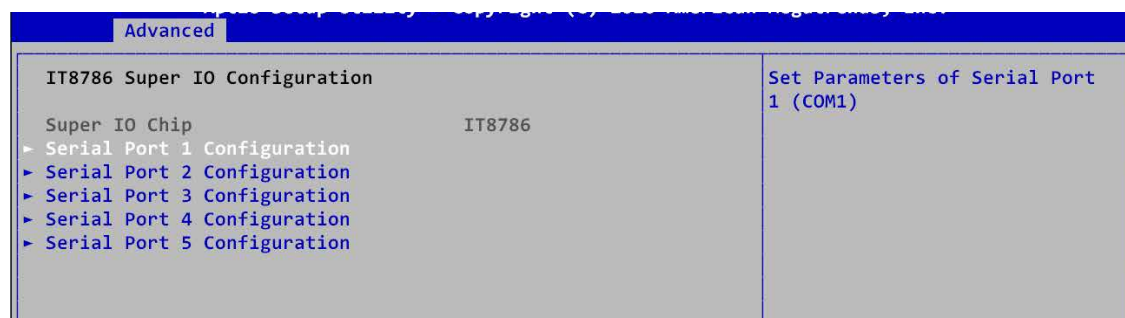

Figure 4-3-5 : Super IO Settings

Serial Port 1 Configuration

Set parameters of serial port 1 (COM 1).

Serial Port 2 Configuration

Set parameters of serial port 2 (COM 2).

Serial Port 3 Configuration

Set parameters of serial port 3 (COM 3).

Serial Port 4 Configuration

Set parameters of serial port 4 (COM 4).

Serial Port 5 Configuration

Set parameters of serial port 5 (COM 5).

4.3.6 Hardware Monitor

The IT8786 SIO features an enhanced hardware monitor providing thermal, fan speed, and system voltages' status monitoring.

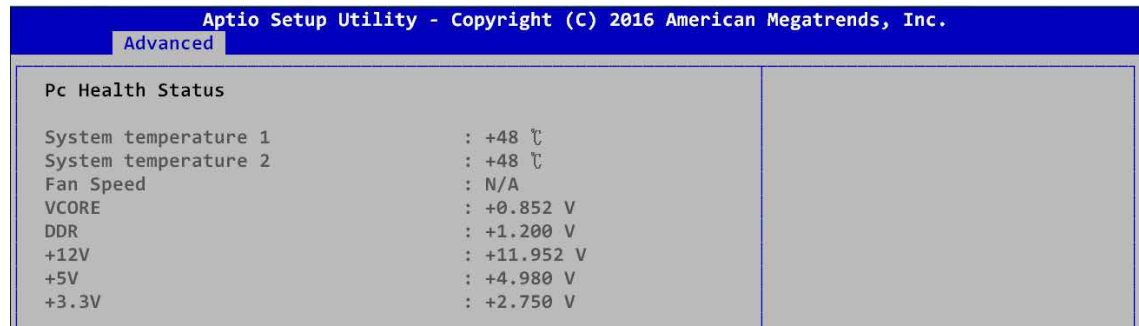

Figure 4-3-6 : Hardware Monitor Settings

4.3.7 Serial Port Console Redirection

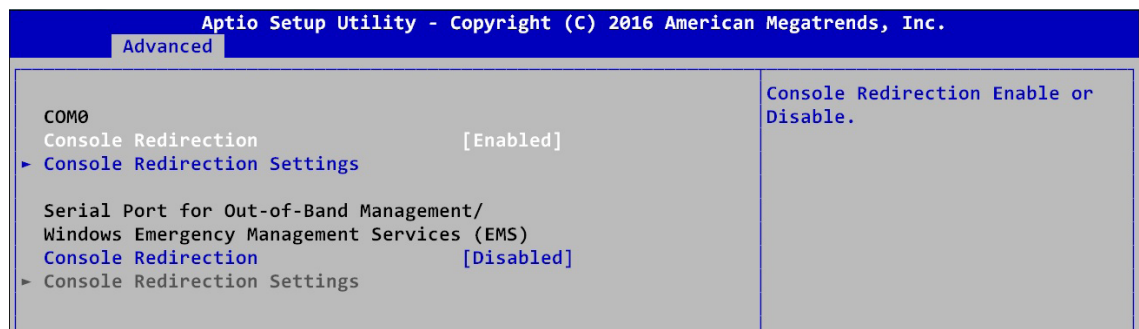

Figure 4-3-7 : Serial Port Console Redirection Settings

Console Redirection

Console redirection enable or disable.

Console Redirection Settings

The settings specify how the host computer and the remote computer (which the user is using) will exchange data. Both computers should have the same or compatible settings.

4.3.8 CPU Configuration

Display CPU-related information and features supported.

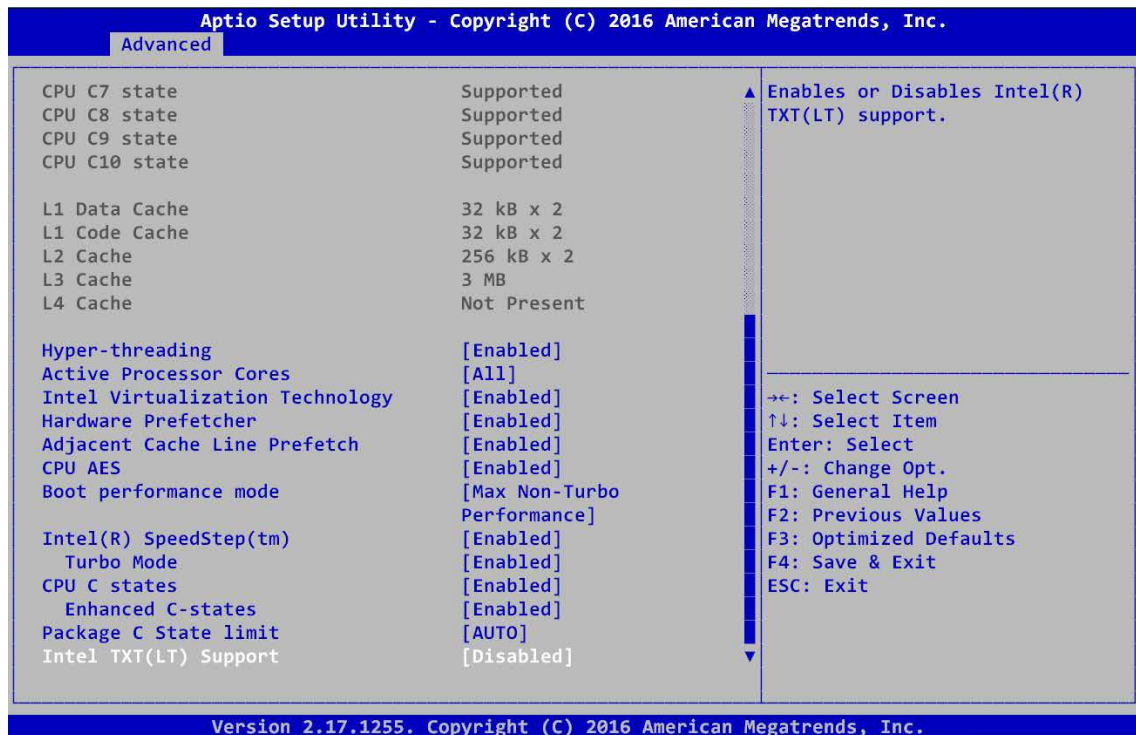

Figure 4-3-8 : CPU Function Settings

Hyper-threading

Enabled for Windows XP and Linux (OS optimized for Hyper-Threading Technology) and disabled for other OS (OS not optimized for Hyper-Threading Technology). When disabled only one thread per enabled core is enabled.

Active Processor Cores

Number of cores to enable in each processor package.

Intel Virtualization Technology

When enabled, a VMM can utilize the additional hardware capabilities provided by Vanderpool Technology.

Hardware Prefetcher

To turn on/off the MLC streamer prefetcher.

Adjacent Cache Line Prefetch

To turn on/off prefetching of adjacent cache lines.

CPU AES

Enable/disable CPU Advanced Encryption Standard instructions.

Boot performance mode

Select the performance state that the BIOS will set before OS handoff.

Intel SpeedStep

Allows more than two frequency ranges to be supported.

Turbo Mode

Turbo Mode.

CPU C state

Enable or disable CPU C states.

Enhanced C-states

Enable/disable C1E. When enabled, CPU will switch to minimum speed when all cores enter C-State.

Package C State limit

Package C State limit.

Intel TXT(LT) Support

Enables or disabled Intel TXT(LT) support.

4.3.9 Intel TXT Information

Display Intel TXT information.

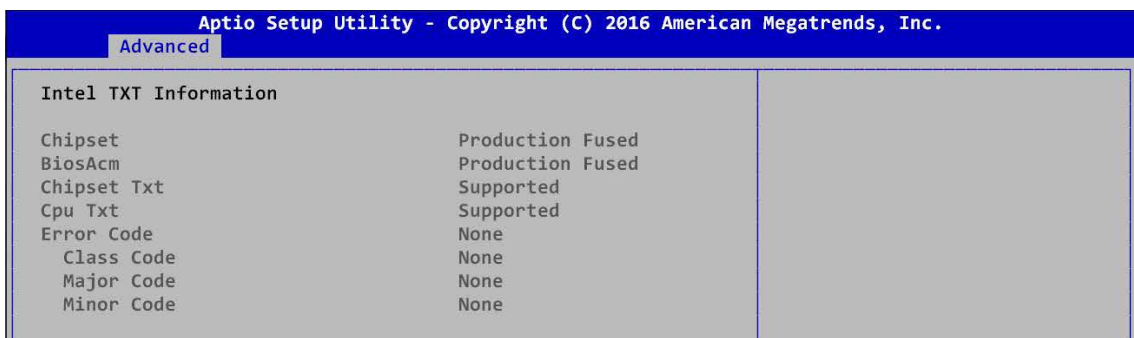

The screenshot shows the Aptio Setup Utility interface with the 'Advanced' tab selected. The 'Intel TXT Information' section is displayed, showing the following details:

Intel TXT Information	
Chipset	Production Fused
BiosAcm	Production Fused
Chipset Txt	Supported
Cpu Txt	Supported
Error Code	None
Class Code	None
Major Code	None
Minor Code	None

Figure 4-3-9 : Intel TXT Information

4.3.10 SATA Configuration



Figure 4-3-10 : SATA Devices Settings

Hyper-threading

Enabled for Windows XP and Linux (OS optimized for Hyper-Threading Technology) and disabled for other OS (OS not optimized for Hyper-Threading Technology). When disabled only one thread per enabled core is enabled.

SATA Controller(s)

Enable or disable SATA Device.

SATA Mode Selection

Determines how SATA controller(s) operate.

Software Feature Mask Configuration

RAID OROM/RST driver will refer to the SWFM configuration to enable or disable the storage features.

Aggressive LPM Support

Enable PCH to aggressively enter link power state.

Options for each SATA port :

Port 0

Enable or disabled SATA Port.

Spin Up Device

On an edge detect from 0 to 1, the PCH starts a COMRESET initialization sequence to the device.

SATA Device Type

Identify the SATA port is connected to Solid State Drive or Hard Disk Drive.

4.3.11 Acoustic Management Configuration

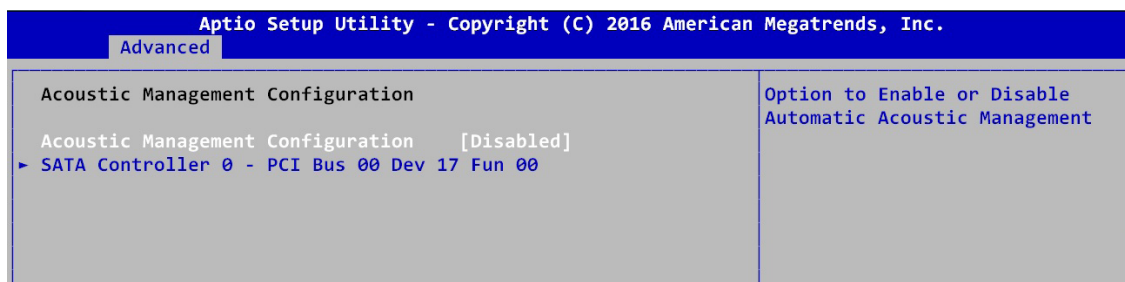

Figure 4-3-11 : Acoustic Management Settings

Acoustic Management Configuration

Option to enable or disable Automatic Acoustic Management.

4.3.12 Network Stack Configuration

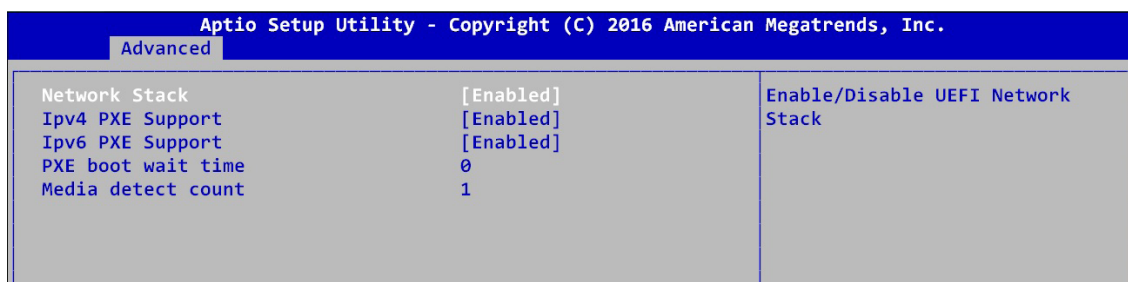

Figure 4-3-12 : Network Stack Settings

Network Stack

Enable/disable UEFI Network Stack.

Ipv4 PXE Support

Enable Ipv4 PXE Boot Support. If disabled IPV4 PXE boot option will not be created.

Ipv6 PXE Support

Enable Ipv6 PXE Boot Support. If disabled IPV6 PXE boot option will not be created.

PXE boot wait time

Wait time to press ESC key to abort the PXE boot.

Media detect count

Number of times presence of media will be checked.

4.3.13 CSM Configuration

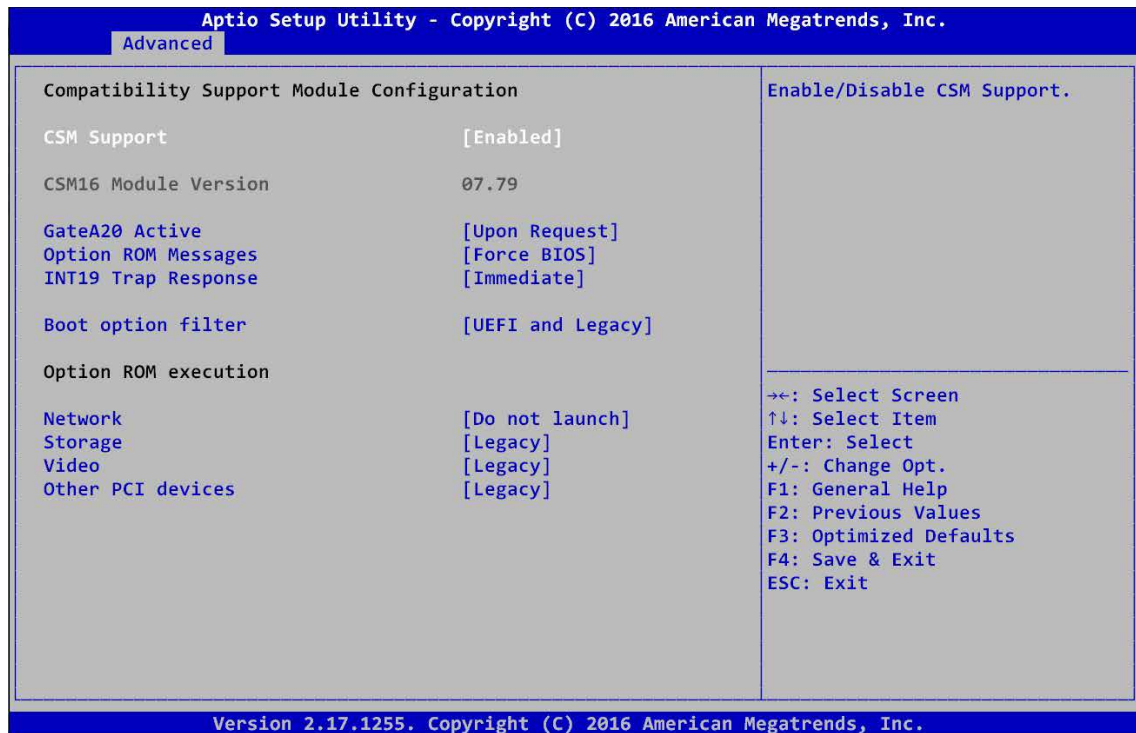

Figure 4-3-13 : CSM Settings

Network Stack

Enable/disable UEFI Network Stack.

CSM Support

Enable/disable CSM Support.

GateA20 Active

UPON REQUEST - GA20 can be disabled using BIOS services.

ALWAYS - do not allow disabling GA20; this option is useful when any RT code is executed above 1MB.

Option ROM Messages

Set display mode for Option ROM.

INT19 Trap Response

BIOS reaction on INT19 trapping by Option ROM:

IMMEDIATE - execute the trap right away;

POSTPONED - execute the trap during legacy boot.

Boot option filter

This option controls Legacy/UEFI ROMs priority.

Network

Controls the execution of UEFI and Legacy PXE OpROM.

Storage

Controls the execution of UEFI and Legacy Storage OpROM.

Video

Controls the execution of UEFI and Legacy Video OpROM.

Other PCI devices

Determines OpROM execution policy for devices other than network, storage, or video.

4.3.14 USB Configuration

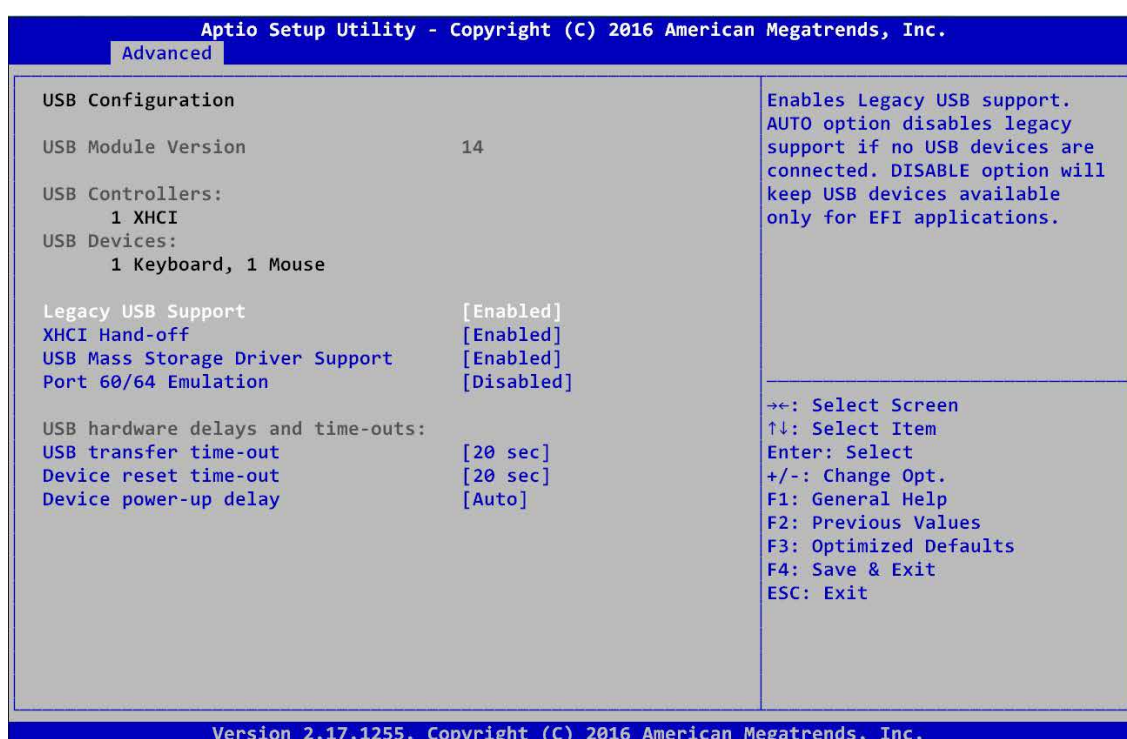

Figure 4-3-14 : USB Settings

Network Stack

Enable/disable UEFI Network Stack.

Legacy USB Support

Enables Legacy USB support.

AUTO option disables legacy support if no USB devices are connected.

DISABLE option will keep USB devices available only for EFI applications.

XHCI Hand-off

This is a workaround for OS-es without XHCI hand-off support. The XHCI ownership change should be claimed by XHCI driver.

USB Mass Storage Driver Support

Enable/disable USB Mass Storage Driver Support.

Port 60/64 Emulation

Enables I/O port 60h/64h emulation support. This should be enabled for the complete USB keyboard legacy support for non-USB aware OSes.

USB transfer time-out

The time-out value for control, bulk, and interrupt transfers.

Device reset time-out

USB mass storage device Start Unit command time-out.

Device power-up delay

Maximum time the device will take before it properly reports itself to the host controller. 'Auto' uses default value: for a root port it is 100 ms, for a hub port the delay is taken from hub descriptor.

4.4 Chipset

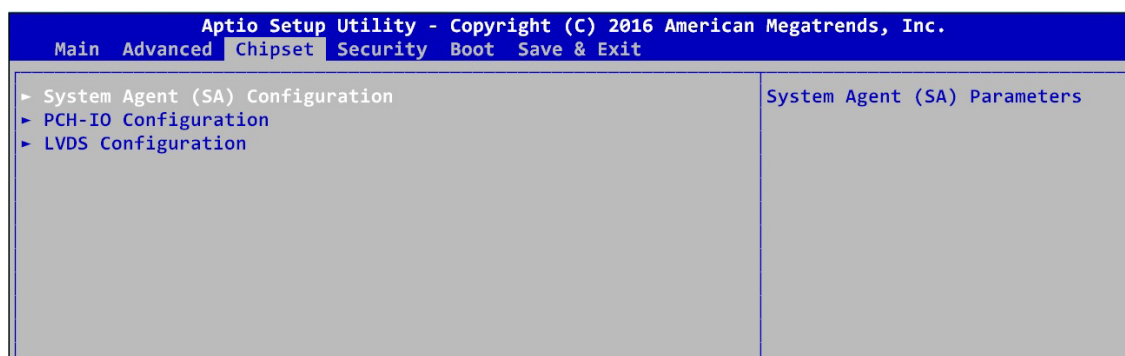

Figure 4-4 : BIOS Chipset Menu

System Agent (SA) Configuration

System Agent (SA) Parameters.

PCH-IO Configuration

PCH Parameters.

LVDS Configuration

LVDS Configuration.

4.4.1 System Agent (SA) Configuration

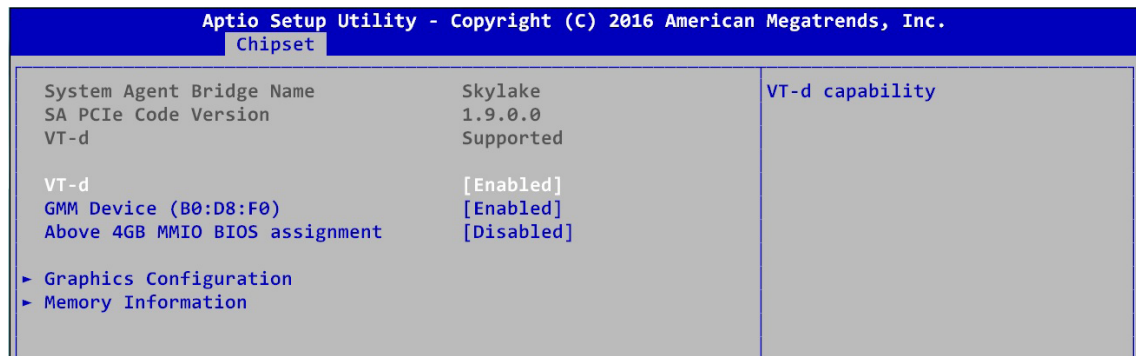

Figure 4-4-1 : USB Settings

VT-d

VT-d capability.

GMM Device (B0:D8:F0)

Enable/disable SA GMM Device.

Above 4GB MMIO BIOS assignment

Enable/disable above 4GB Memory MappedIO BIOS assignment. This is disabled automatically when Aperture Size is set to 2048MB.

4.4.2 Graphics Configuration of System Agent (SA)

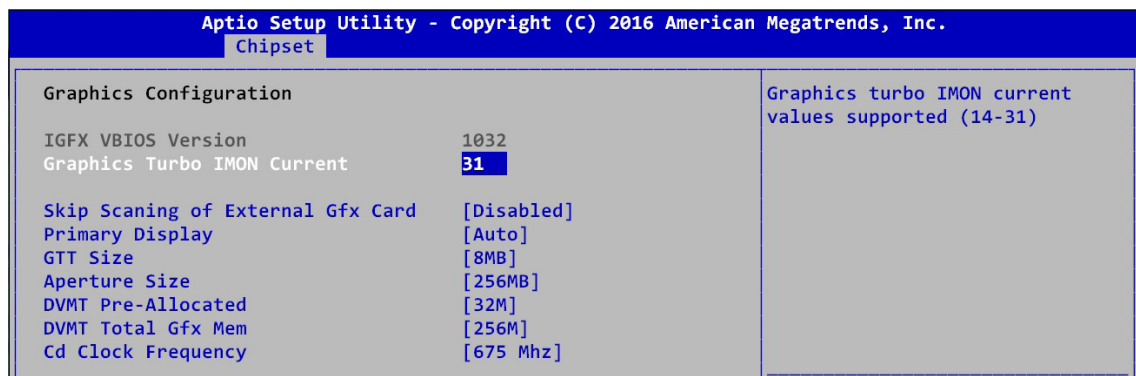

Figure 4-4-1 : USB Settings

Graphics Turbo IMON Current

Graphics turbo IMON current values supported (14-31).

Skip Scanning of External Gfx Card

If enable, it will not scan for External Gfx Card on PEG and PCH PCIE Ports.

Primary Display

Select which of IGFX/PEG/PCI graphics device should be primary display or select SG for Switchable Gfx.

GTT Size

Select the GTT Size.

Aperture Size

Select the Aperture Size.

Note: Above 4GB MMIO BIOS assignment is automatically enabled when selecting 2048MB aperture. To use this feature, please disable CSM Support.

DVMT Pre-Allocated

Select DVMT 5.0 Pre-Allocated (Fixed) Graphics Memory size used by the Internal Graphics Device.

DVMT Total Gfx Mem

Select DVMT5.0 Total Graphic Memory size used by the Internal Graphics Device.

Cd Clock Frequency

Select the highest Cd Clock frequency supported by the platform.

4.4.3 Memory Information of System Agent (SA)

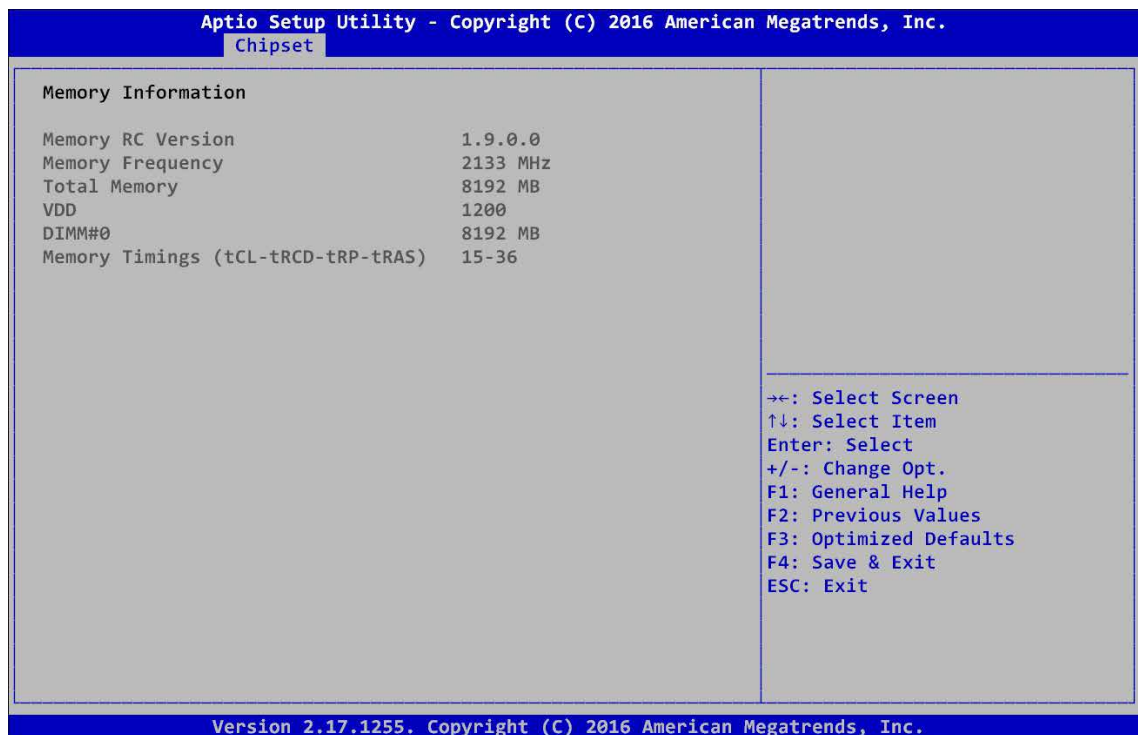

Figure 4-4-3 : Memory Information

Display memory information.

4.4.4 PCH-IO Configuration

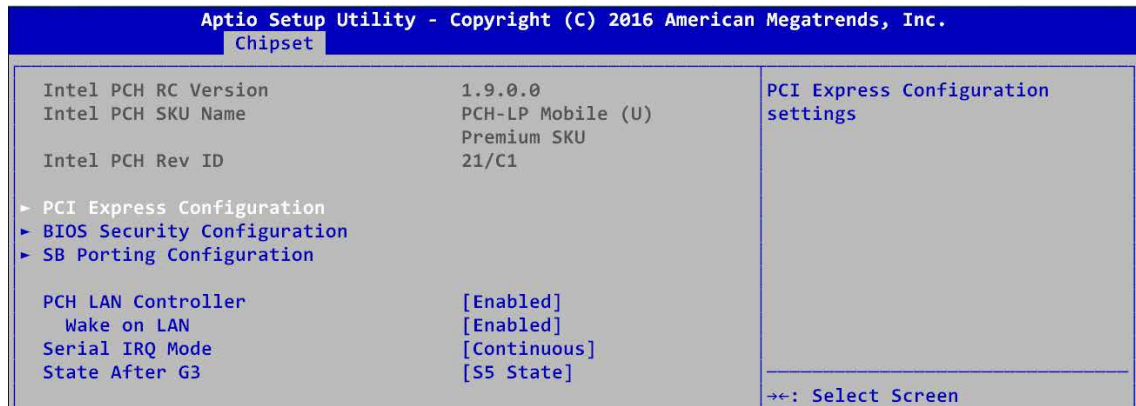

Figure 4-4-4 : USB Settings

PCH LAN Controller

Enable or disable onboard NIC.

Wake on LAN

Enable or disable integrated LAN to wake the system. (The Wake On LAN cannot be disabled if ME is on at Sx state).

Serial IRQ Mode

Configure Serial IRQ Mode.

State After G3

Specify what state to go to when power is re-applied after a power failure (G3 state).

S0 State: Always turn-on the system when power source plugged-in.

S5 State: Always turn-off the system when power source plugged-in

4.4.5 PCI Express Configuration of PCH-IO

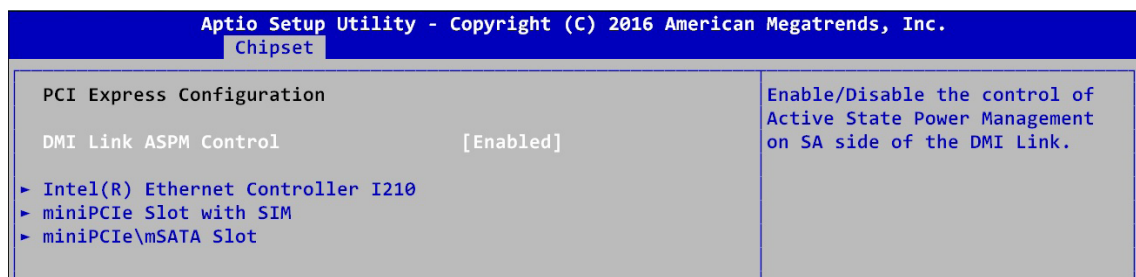

Figure 4-4-5 : PCH-IO Settings

DMI Link ASPM Control

Enable/disable the control of Active State Power Management on SA side of the DMI Link.

Intel Ethernet Controller I210

Intel Ethernet Controller I210 Settings.

Mini PCIe Slot with SIM

Mini PCIe Slot with SIM Settings.

Mini PCIe\ mSATA Slot

Mini PCIe\ mSATA Slot Settings.

4.4.6 BIOS Security Configuration of PCH-IO

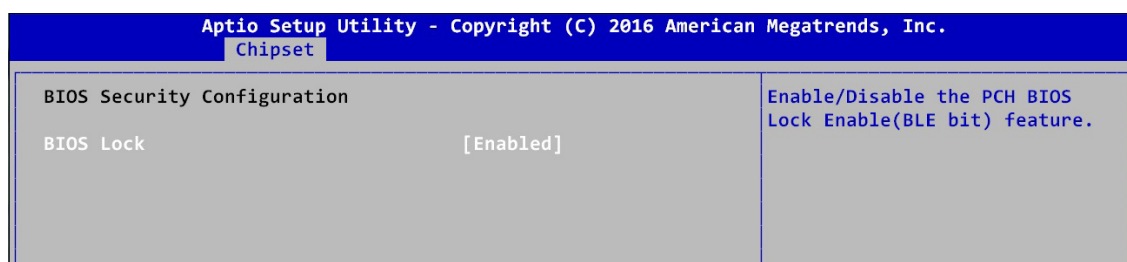

Figure 4-4-6 : BIOS Security Settings

BIOS Lock

Enable/disable the PCH BIOS lock enable (BLE bit) feature.

4.4.7 SB Porting Configuration of PCH-IO

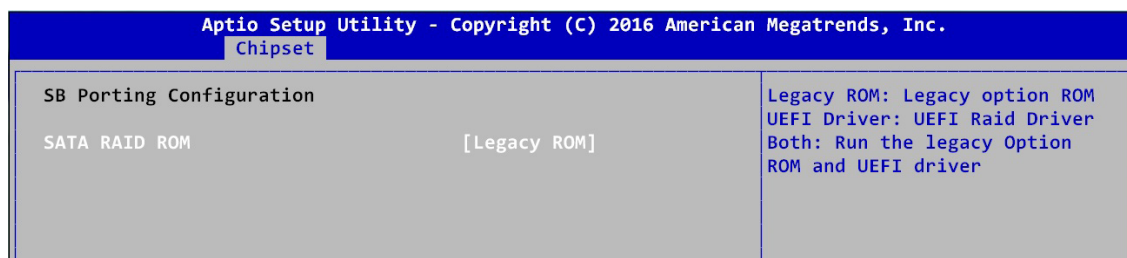

Figure 4-4-7 : RAID ROM Settings

SATA RAID ROM

Legacy ROM: Legacy option ROM

UEFI Driver: UEFI Raid Driver

Both: Run the legacy Option ROM and UEFI driver.

4.4.8 LVDS Configuration

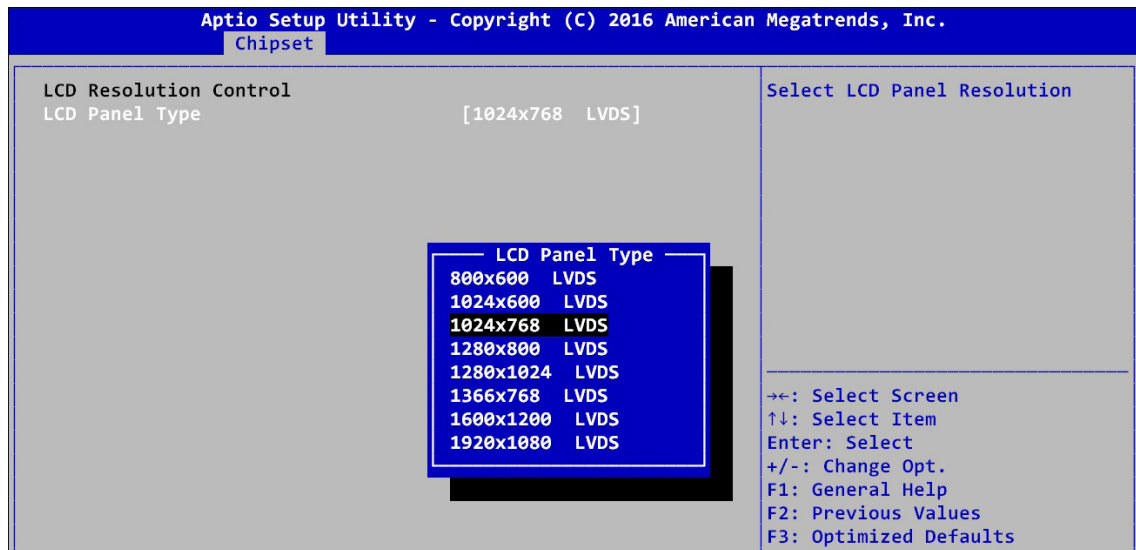

Figure 4-4-8 : LVDS Panel Settings

LCD Panel Type

Select LCD Panel Resolution.

4.5 Security

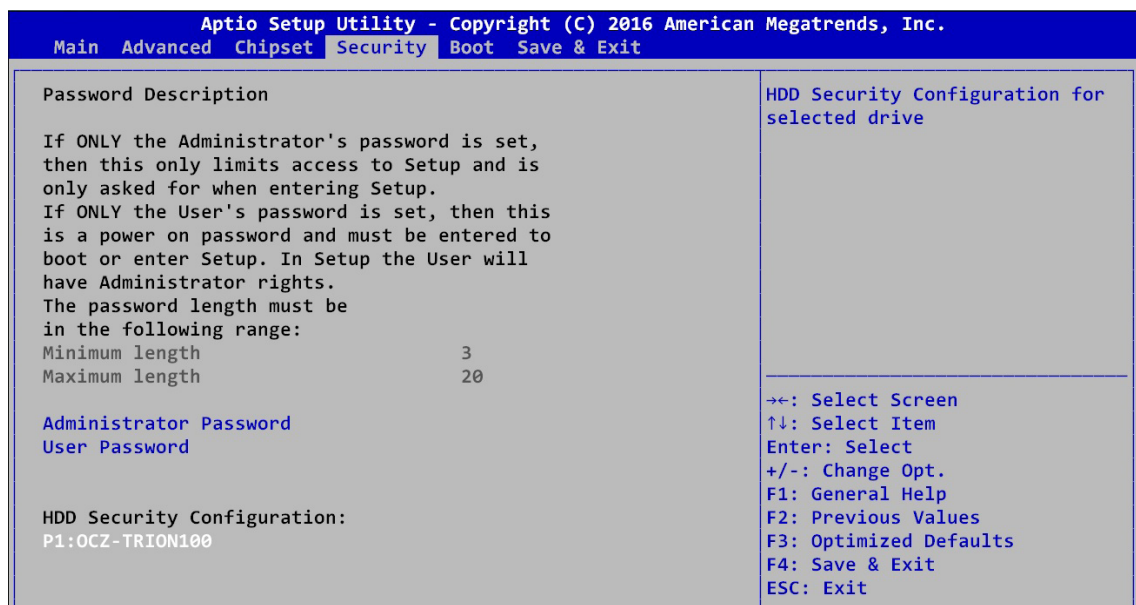

Figure 4-5 : BIOS Security Menu

Administrator Password

Set Administrator Password.

User Password

Set User Password.

4.5.1 HDD Security Configuration

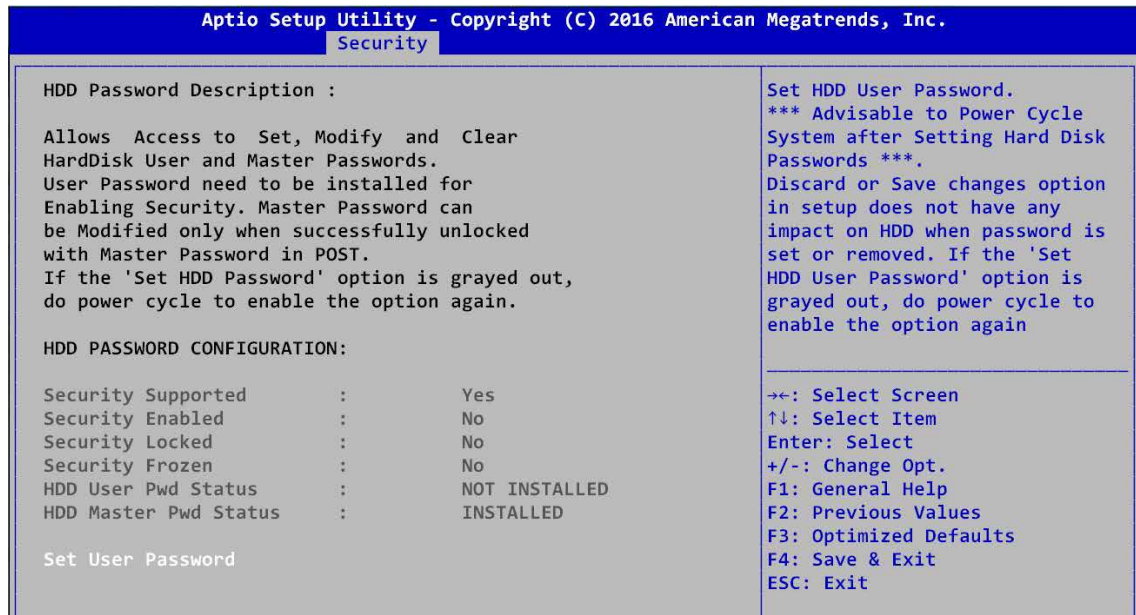

Figure 4-5-1 : HDD Security Settings

Set User Password

Set HDD user password.

Advisable to Power Cycle System after Setting Hard Disk Passwords.

Discard or save changes option in setup does not have any impact on HDD when password is set or removed. If the 'Set HDD User Password' option is grayed out, do power cycle to enable the option again.

4.6 Boot

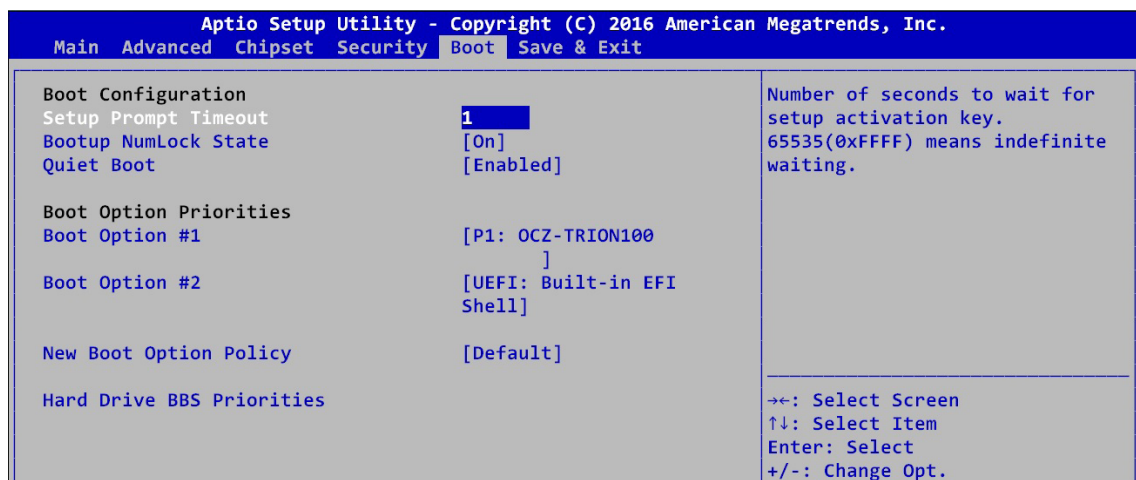

Figure 4-6 : BIOS Boot Menu

Setup Prompt Timeout

Number of seconds to wait for setup activation key. 65535(0xFFFF) means indefinite waiting.

Bootup NumLock State

Select the keyboard NumLock state.

Quiet Boot

Enables or disables Quiet Boot option.

Boot Option #x

Sets the system boot order.

New Boot Option Policy

Controls the placement of newly detected UEFI boot options.

Hard Drive BBS Priorities

Set the order of the legacy devices in this group.

4.7 Save & Exit

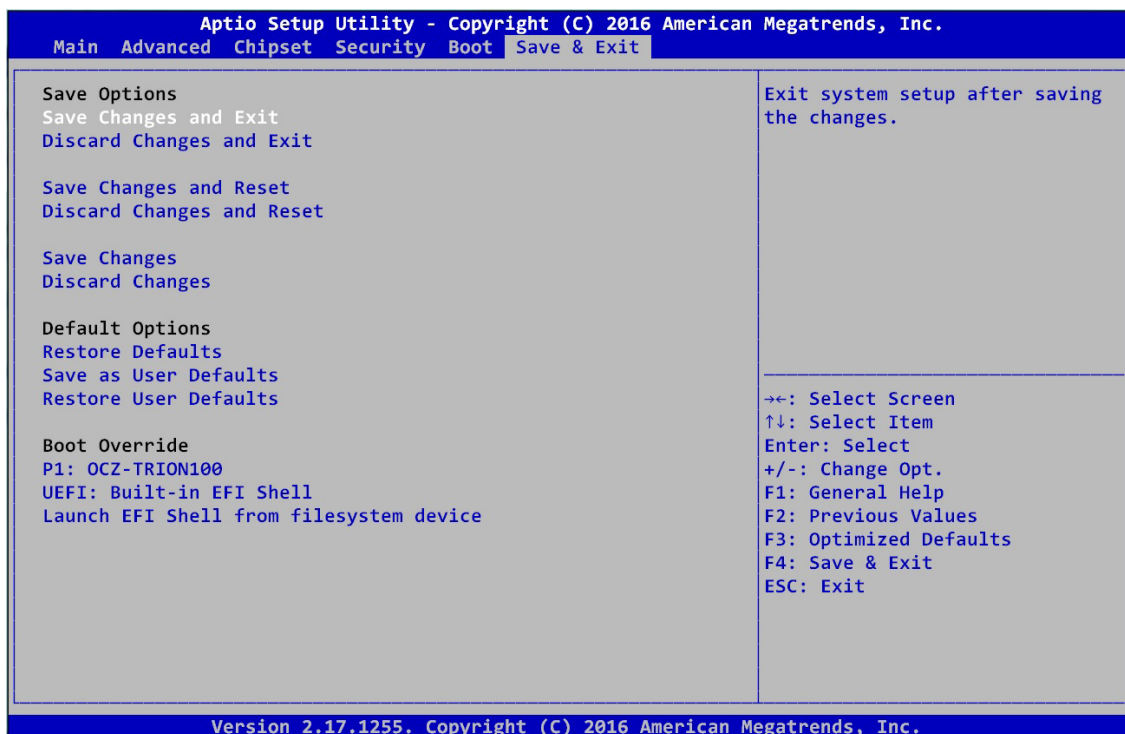

Figure 4-7 : Bios Save and Exit Menu

Save Changes and Exit

Exit system setup after saving the changes.

Discard Changes and Exit

Exit system setup without saving any changes.

Save Changes and Reset

Reset the system after saving the changes.

Discard Changes and Reset

Reset system setup without saving any changes.

Save Changes

Save changes done so far to any of the setup options.

Discard Changes

Discard changes done so far to any of the setup options.

Default Options :

Restore Defaults

Restore/load default values for all the setup options.

Save as User Defaults

Save the changes done so far as User Defaults.

Restore User Defaults

Restore the User Defaults to all the setup options.

A

APPENDIX A : Watchdog Function

A.1 Function Description

The RES-1000 offers a watchdog timer.

A.2 Software Package Contain

Distribution folder include x32 and x64 versions, use batch file for installation.

There are included as followed :

Win7_32.bat :

Installation for 32-bit driver

Win7_64.bat :

Windows update package which driver required (need to restart), and Installation for 64-bit driver

Win8_32.bat, Win8_64.bat :

Installation for driver, and guideline to Framework 3.5 distribution for sample

Win10_32.bat, and Win10_64.bat :

Installation for driver, and installation to Framework 3.5 distribution for sample

Uninstall_32.bat, and Uninstall_64.bat :

Uninstallation for driver

Run batch file as Administrator.

Support Windows 7 above.

Make sure Windows version before installation.

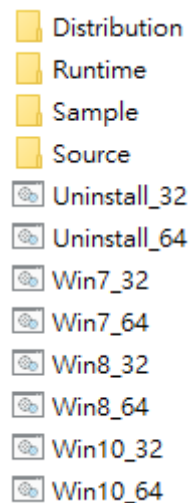

Runtime folder include head file for software developer or System Integration.

Sample folder include sample program, driver library, and API library.

Source folder include sample program source code that compile on Visual Studio 2008.

A.3 Sample

Sample folder include x32 and x64 versions, as shown below :

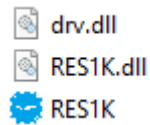

Sample RES1K.exe, as shown below :

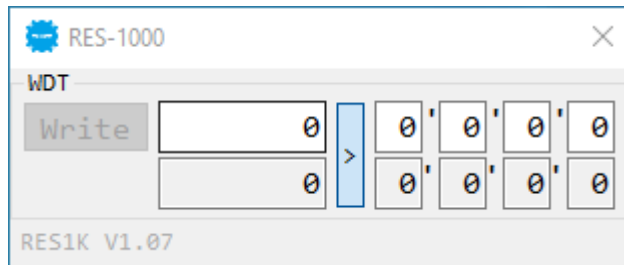

WDT group :

Write button :

Set WDT when WDT setup text is valid.

Stop button :

Cancel WDT and counting.

Use after Write button action.

WDT setup text :

User setting, WDT value, unit : second.

Use for Write button activate.

WDT counting text (read only) :

WDT counting by program timer after set WDT.

Shown after Write button action.

WDT setup day format texts (user setting) :

User setting, WDT value, format : day'hour'minute'second.

WDT counting day format text (read only) :

WDT counting, format : day'hour'minute'second.

B

APPENDIX B : Software Functions

B.1 Driver API Guide

In Runtime folder, on RES1K.h :

 _DLL_IMPORT_ definition is used on LoadLibrary API for RES1K.dll.

 RES1K_EXPORTS definition is used on RES1K.dll building.

BOOL Initial (BYTE Isolate_Type, BYTE DIO_NPN)

Initial machine for DIO, watchdog timer, and POE

 Isolate_Type : DIO type

 1 : Isolated DIO;

 0 : Non-Isolated DIO

 DIO_NPN : DI/DO type

 1 : PNP (Source) mode for European rule;

 0 : NPN (Sink) mode for Japanese rule

Return :

 TRUE (1) : Success;

 FALSE (0) : Fail (Driver not exists, or initial error (version is too old, or machine not match))

BOOL GetWDT (DWORD *WDT)

Get watchdog timer setup

 WDT : watchdog timer setup

 Unit : second. (Range : 0 ~ 65535 sec, 1093 ~ 65535 min (=65580 ~ 3932100 sec))

Return :

 TRUE (1) : Success;

 FALSE (0) : Fail (Initial error, or call by pointer error, or hardware problem)

BOOL SetWDT (DWORD WDT)

Set watchdog timer setup

 WDT : watchdog timer setup

 Unit : second. (Range : 1 ~ 65535 sec, 1093 ~ 65535 min (=65580 ~ 3932100 sec))

Return :

 TRUE (1) : Success;

 FALSE (0) : Fail (Initial error, or setup 0 error, or hardware problem)

BOOL CancelWDT ()

Cancel watchdog timer

Return :

 TRUE (1) : Success;

 FALSE (0) : Fail (Initial error, or hardware problem)

C

APPENDIX C : RAID Functions

C.1 SATA Mode for RAID

Please select SATA Device to RAID mode on BIOS menu.
Advanced → SATA Configuration → SATA Mode Selection

Main	Advanced	Chipset	Boot	Security	Save & Exit
SATA Controller(s) [Enabled]					Item Specific Help
SATA Model Selection [AHCI]					

C.2 OS Installation

The system is featured with three SATA, include two internal SATA, 1 mSATA
You can select one of SATA ports for OS installation
We used internal SATA for Windows 10 OS installation as an example.

C.3 To Install All Device Drivers of the System

The instructions are as follows :

1. To install Chipset driver
2. To install VGA driver
3. To install ME driver (if available)
4. To install Network driver
5. To install Audio driver

C.4 To Install "Intel Rapid Storage Technology" Software

You can get the latest information and the software directly from Intel website.

http://www.intel.com/p/en_US/support/highlights/chpsts/ims

The RAID environment has been done if you completed the steps above.

C.5 To Insert SATA HDD for RAID 1

Please notice, you can use three SATA ports for SATA storage devices.

C.6 To Create RAID Volume on "Rapid Storage Technology" Software

The system is featured with three SATA HDD's for RAID volume, so there are two options to choose on this page. Let's take RAID 1 as an example, select "RAID 1".



C.7 Disk Management : Partition the Disk

After RAID 1 volume created, you can see the figure of SATA device allocation.

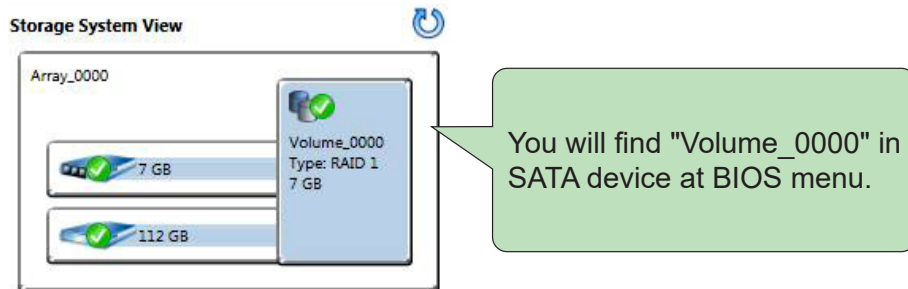

To start Disk Management tool and select "Initialize Disk".
Then add "Logical Device" for Windows access.

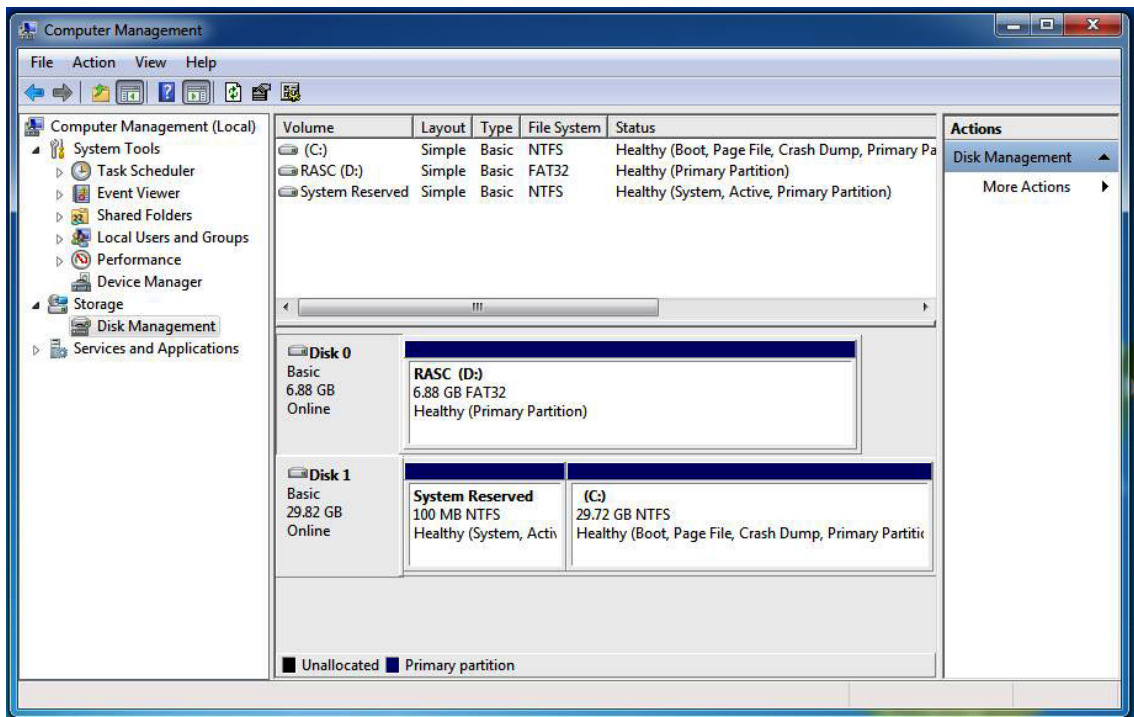

C.8 If One SATA HDD on RAID Volume is Out-of-use

After RAID 1 volume created, you can see the figure of SATA device allocation.

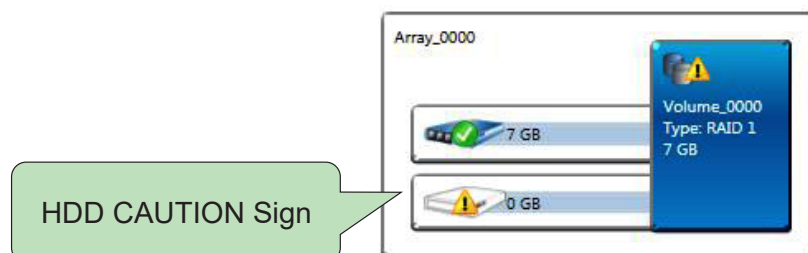

C.9 Recovery and Auto Re-build When Use the SAME RAID HDD



C.10 Recovery and Auto Re-build When Use DIFFERENT RAID HDD

There is a warning will pop-up to ask you if the disk is not a member of original RAID volume.

If you press "Rebuild", it will replace the broken SATA HDD to the last one SATA HDD of RAID volume.

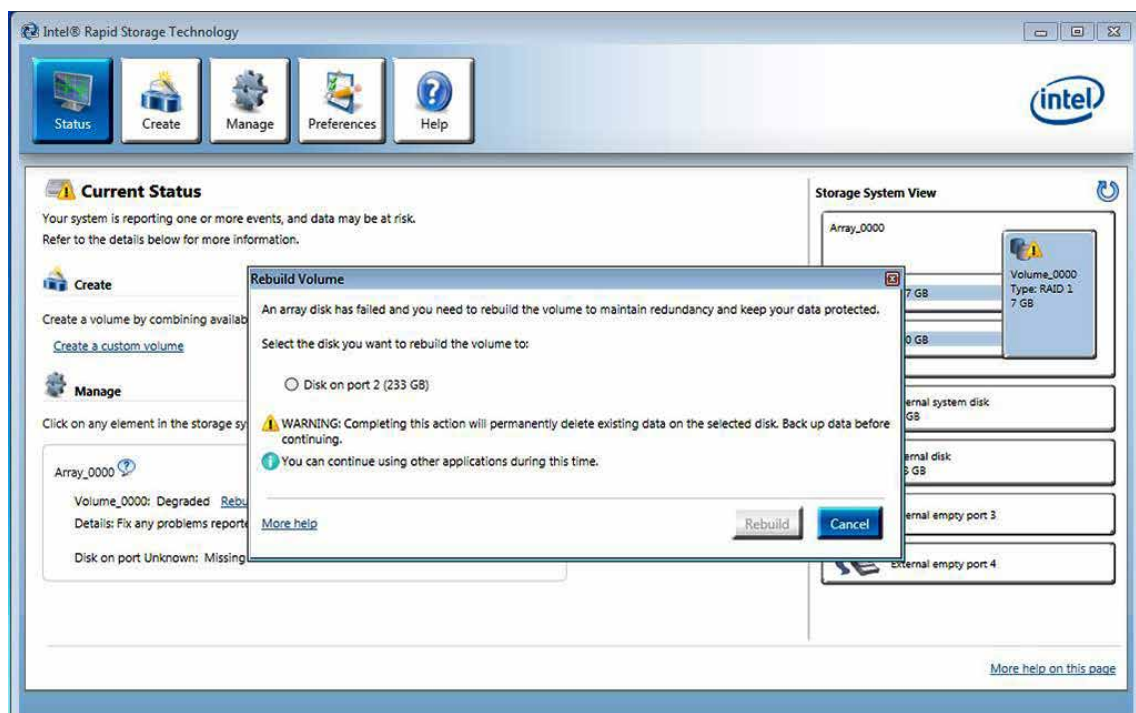

D

APPENDIX D : Power Consumption

Testing Board	RES-1000
RAM	Transcend 8GB
SATA 0	TOSHIBA SSD THNS064GE4BBDC 64GB
SATA 1	HITACHI HTS542580K9SA00 80G
USB3.0 -1	USB Flash Transcend 3.0 8GB
USB3.0 -2	USB Flash Transcend 3.0 8GB
USB3.0 -3	USB Flash Transcend 3.0 8GB
USB3.0 -4	USB Flash Transcend 3.0 8GB
USB2.0-1	USB Flash ADATA 8GB
USB2.0-2	Logitech M105 Mouse
LAN1(I219)	1.0 Gbps
LAN2(I210)	1.0 Gbps
Graphics Output	DVI
Power plan	Balance(Windows8.1 Power Plan)
Power Source	Chroma 62006P-100-25

D.1 Intel® Core™ i7-6600U

Intel® Core™ i7-6600U@2.6GHz (4M Cache, up to 3.40 GHz)

Power on and boot to Win8.1 64bit

CPU	Power Input	Standby Mode		Idle Status : CPU usage less 3%		Run 100% CPU Usage	
		Max Current	Max Consumption	Max Current	Max Consumption	Max Current	Max Consumption
i7-6600U	12V	0.327A	03.92W	0.874A	10.49W	1.993A	23.92W
i7-6600U	24V	0.279A	06.70W	0.571A	13.70W	1.121A	26.90W
i7-6600U	28V	0.274A	07.67W	0.504A	14.11W	1.002A	28.06W
i7-6600U	36V	0.258A	09.29W	0.443A	15.95W	0.796A	28.66W

D.2 Intel® Core™ i5-6300U

Intel® Core™ i5-6300U @2.4GHz (3M Cache, up to 3.00 GHz)

Power on and boot to Win8.1 64bit

CPU	Power Input	Standby Mode		Idle Status : CPU usage less 3%		Run 100% CPU Usage	
		Max Current	Max Consumption	Max Current	Max Consumption	Max Current	Max Consumption
i5-6300U	12V	0.335A	04.02W	0.854A	10.25W	2.091A	25.09W
i5-6300U	24V	0.284A	06.82W	0.580A	13.92W	1.151A	27.62W
i5-6300U	28V	0.276A	07.73W	0.514A	14.39W	1.050A	29.40W
i5-6300U	36V	0.259A	09.32W	0.445A	16.03W	0.839A	30.20W

D.3 Intel® Celeron® 3955U

Intel® Celeron® Processor 3955U (2M Cache, 2.00 GHz)

Power on and boot to Win8.1 64bit

CPU	Power Input	Standby Mode		Idle Status : CPU usage less 3%		Run 100% CPU Usage	
		Max Current	Max Consumption	Max Current	Max Consumption	Max Current	Max Consumption
3955U	12V	0.338A	04.06W	0.894A	10.73W	1.712A	20.54W
3955U	24V	0.296A	07.10W	0.570A	13.68W	0.976A	23.42W
3955U	28V	0.291A	08.15W	0.532A	14.90W	0.843A	23.60W
3955U	36V	0.274A	09.86W	0.456A	16.42W	0.734A	26.42W

E

APPENDIX E : Install Win11 (BIOS TPM Setting)

Step 1 Click on “Advanced”, then click on “PCH-FW Configuration”

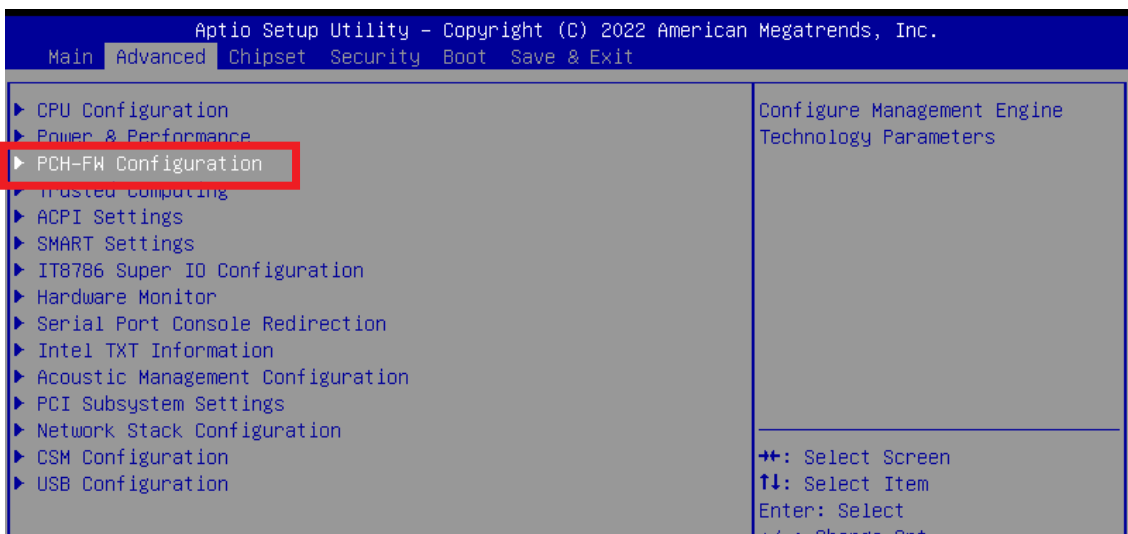

Step 2 Click on “PTT Configuration”

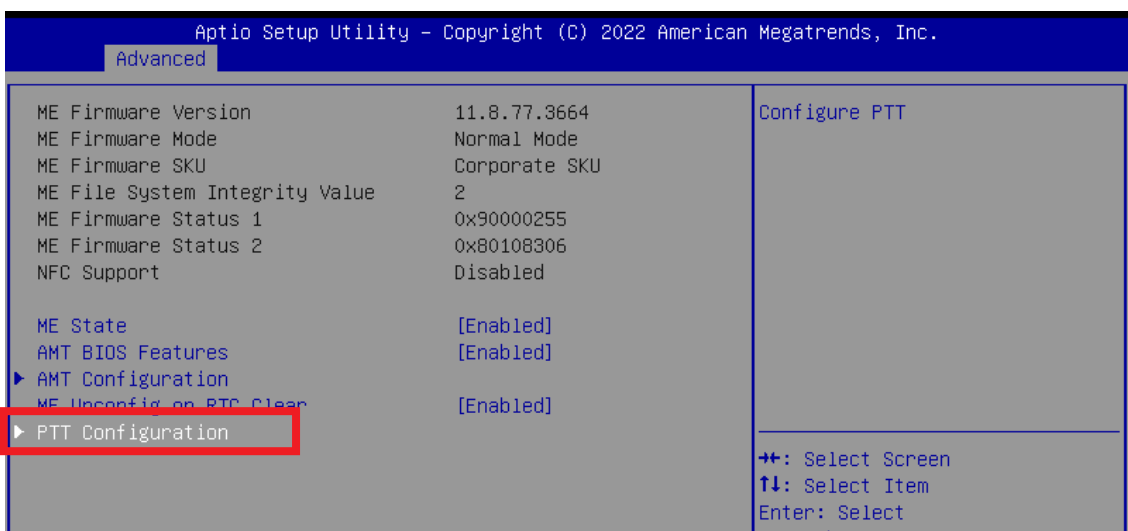

Step 3 Click on “dTPM” (TPM Device Selection)

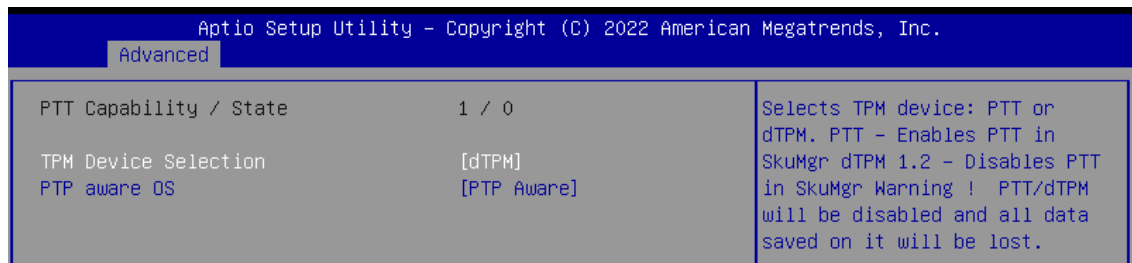
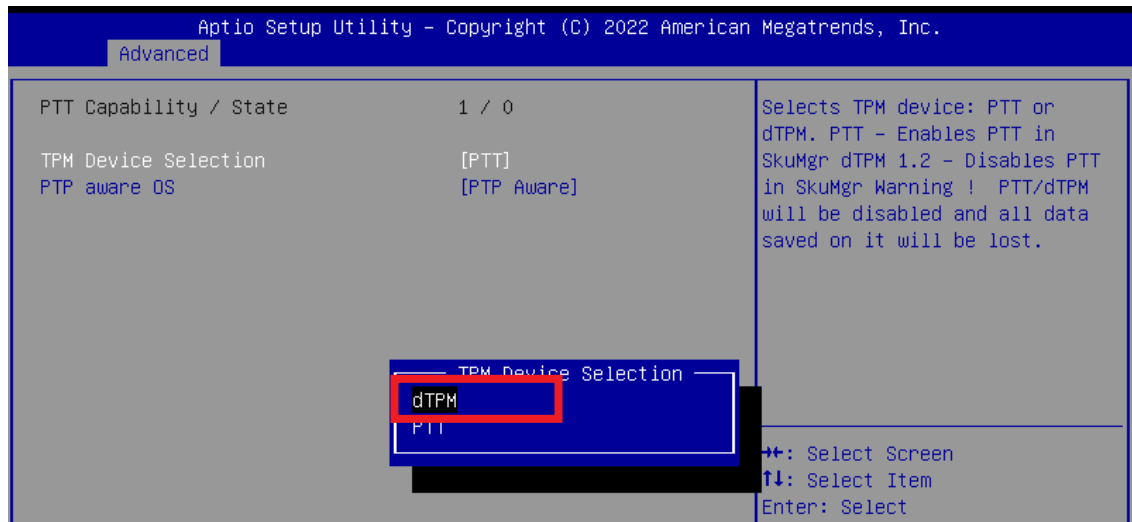

Step 4 Please save the BIOS settings by pressing F4. Please press Enter when the pop-up window which asks “Save configuration and exit?” appears. The computer will then restart.

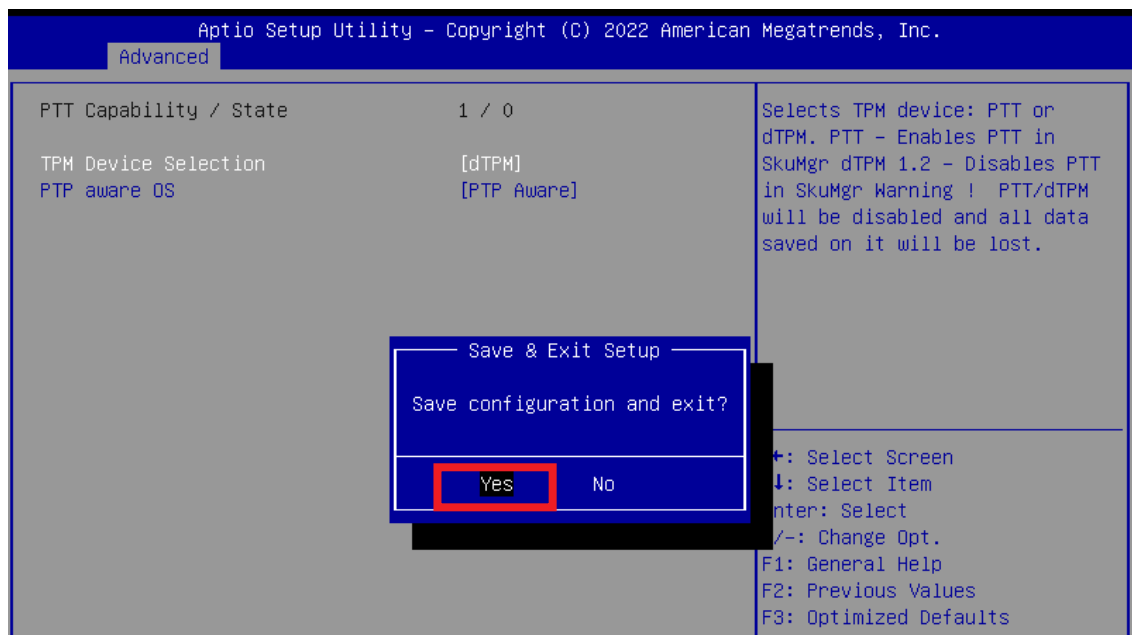

Step 5 Click on “Trusted Computing”

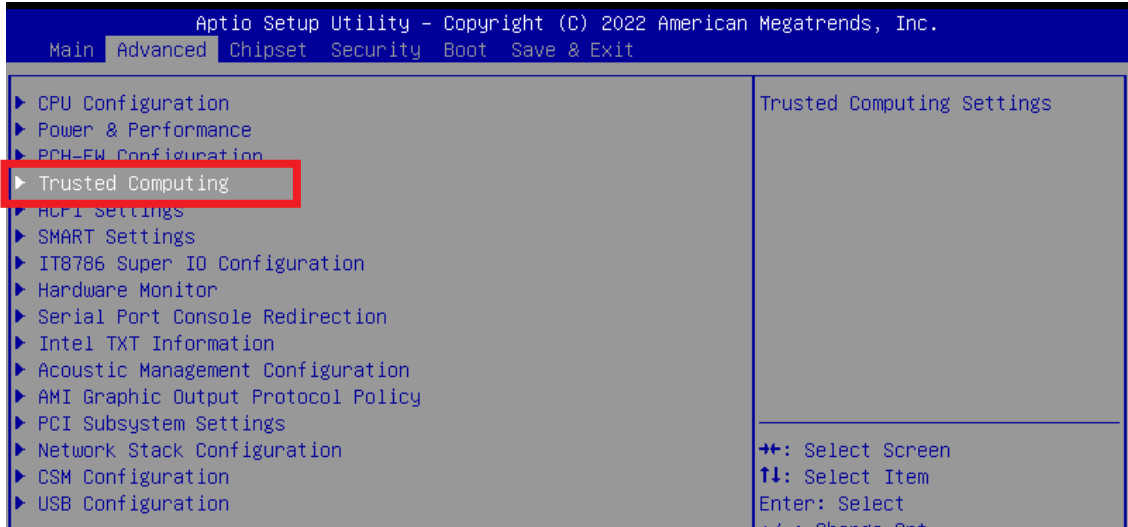

Step 6 If the window shows “TPM2.0 Device Found Firmware Version:5.62”, then the setting is completed.

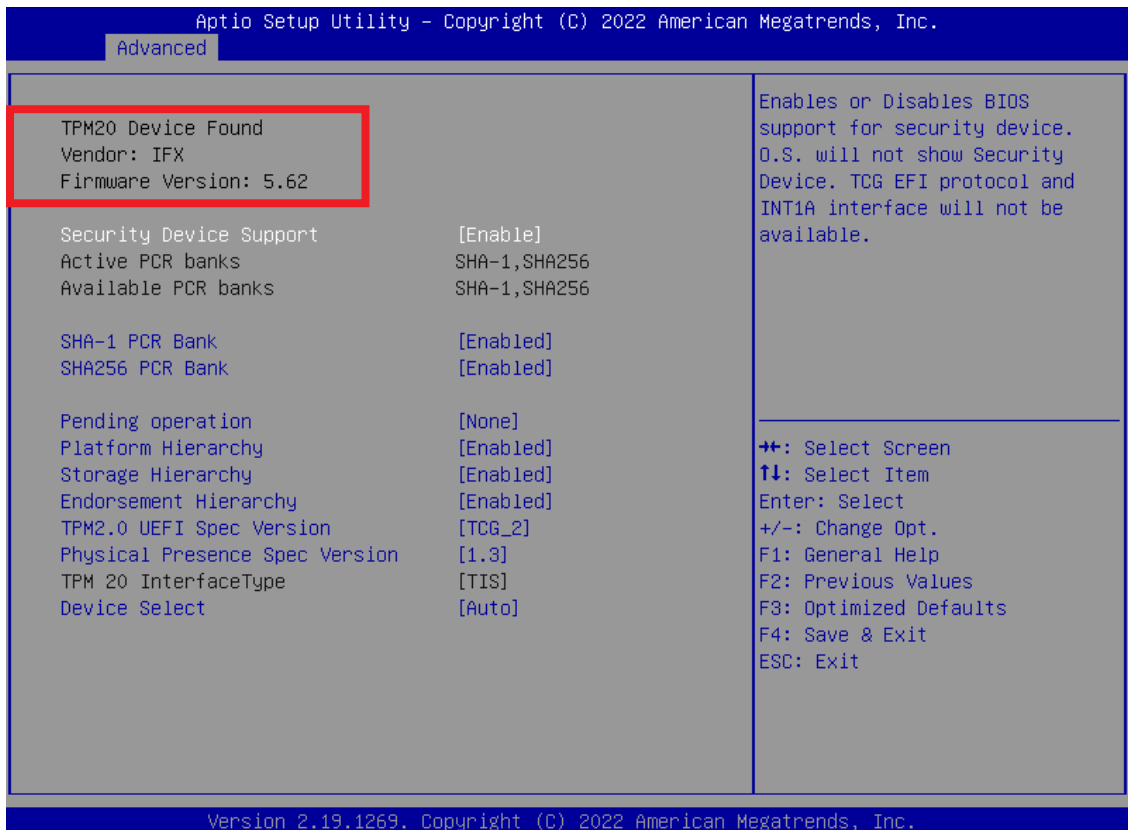

** If more help is needed, please contact Vecow technical support **



For further support information, please visit www.vecow.com

This document is released for reference purpose only.

All product offerings and specifications are subject to change without prior notice.

No part of this publication may be reproduced in any form or by any means, electric, photocopying, or recording, without prior authorization from the publisher.

The rights of all the brand names, product names, and trademarks belong to their respective owners.

© Vecow Co., Ltd. 2022. All rights reserved.